



**LEAD FREE LOW RESISTANCE
CHIP RESISTOR SPECIFICATION**

Reference No. : SYS-ENG-207

Revision No. : Q

ASJ	LEAD FREE LOW RESISTANCE CHIP RESISTOR SPECIFICATION	REV: Q
	DOC NO: SYS-ENG-207	PAGE: 2 of 24

1.0	SCOPE.....	3
2.0	PART NUMBERING SYSTEM.....	3
3.0	RATING.....	3
3.1	Rating Power.....	3
3.2	Standard Atmospheric Condition	4
3.3	Operating Temperature Range.....	4
3.4	Storage Temperature Range.....	4
3.5	Flammability Rating	4
3.6	Moisture Sensitivity Rating Level	4
3.7	RoHS compliance	4
3.8	Resistance Range, Resistance Tolerance and Temperature Coefficient of Resistance	5
3.9	Rated Voltage.....	5
4.0	MARKING ON PRODUCT.....	6
5.0	COMPONENT DIMENSION, CONSTRUCTION AND MATERIALS.....	6
5.1	Dimension	6
5.2	Construction.....	7
5.3	Material	7
6.0	ELECTRICAL CHARACTERISTICS AND TEST CONDITIONS.....	8-11
6.1	Soldering Profile	12
6.1.1	Flow Soldering	12
6.1.2	Reflow Soldering	12
7.0	TAPING	13
7.1	Structure of Taping	13
7.2	Materials	13
7.3	Leader and Trailer Tape	14
7.4	Position of Taped Component	14
7.5	Tape Dimension	15-16
7.6	Performance of Taping	17
7.7	Packaging	18
7.7.1	Standard Packaging Pan Size	18
7.7.2	Identification.....	18-19
7.7.3	Packaging Reel Box.....	19
7.7.4	Reel Dimension	20
8.0	Surface Mount Land Patterns	21
8.1	Test Board for 4 Wire CR16 and CR21	21
8.2	Test Board for 4 Wire CR32 and CR40	22
8.3	Test Board for 4 Wire CR50 and CR63	22
8.4	Test Board for Bending Strength Test	23
8.5	Insulating Resistance and Withstanding Voltage Test Fixture	23
9.0	Applicable Standards.....	24

ASJ	LEAD FREE LOW RESISTANCE CHIP RESISTOR SPECIFICATION	REV: Q
	DOC NO: SYS-ENG-207	PAGE: 3 of 24

1. SCOPE

1.1 This specification specifies fixed thick film chip resistor (referred to as resistor hereinafter) for use in electronic equipment. In case there are discrepancies in specifications between this specification and the customer's specifications, the latter shall precede.

2. PART NUMBER SYSTEM

2.1 Part Numbering is made in accordance with the following system:

TYPE	RESISTANCE VALUE CODE	TOLERANCE	PACKAGING
CRXX -	XXXX -	X	X
CR10 - 0402	REFER TO TABLE 3	D - 0.5%	E - 4K REEL
CR12 - 0402		F - 1%	L - 5K REEL
CR16 - 0603		J - 5%	K - 10K REEL
CR18 - 0603			Y - 20K REEL
CR21 - 0805			
CR32 - 1206			
CR40 - 1210			
CR50 - 2010			
CR52 - 2010			
CR63 - 2512			

3. RATING

3.1. Rated Power

Table 1 :

Type	Rated Power	Max. Working Voltage	Max. Overload Voltage
CR10 (0402)	1/16W	50V	100V
CR12 (0402)	1/8W	50V	100V
CR16 (0603)	1/10W	50V	100V
CR18 (0603)	1/5W	50V	100V
CR21 (0805)	1/8W	150V	300V
CR32 (1206)	1/4W	200V	400V
CR40 (1210)	1/3W	200V	400V
CR50 (2010)	3/4W	200V	400V
CR52 (2010)	1W	200V	400V
CR63 (2512)	1W	200V	400V

ASJ	LEAD FREE LOW RESISTANCE CHIP RESISTOR SPECIFICATION	REV: Q
	DOC NO: SYS-ENG-207	PAGE: 4 of 24

Rated Power shall be the load power corresponding to nominal wattage suitable for continuous use at 70°C ambient temperature. In case the ambient temperature exceeds 70°C, reduce the load power in accordance with Derating curve in Fig. 1.

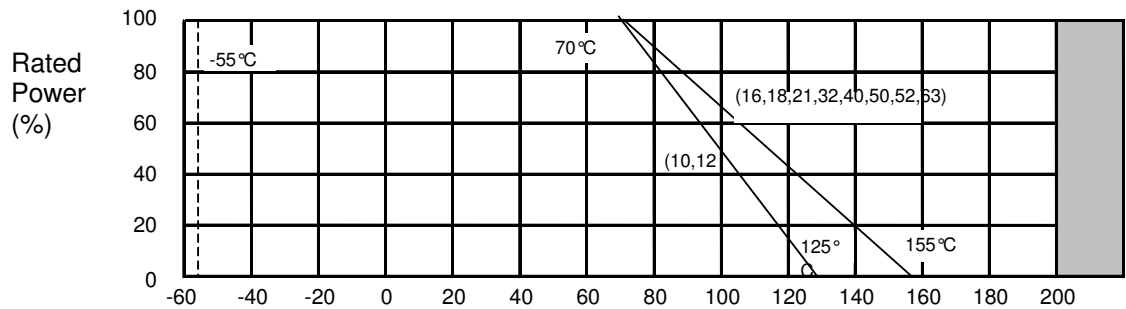

3.2 Standard Atmospheric Condition

Unless otherwise specified, the standard range of atmospheric conditions for making measurements and tests is as follows :

Ambient Temperature = +5°C to +35°C

Relative Humidity = < 85% RH

Air Pressure = 86 to 106kPa

If there may be any doubt about the results, measurement shall be made within the following limits :

Ambient Temperature = 20±2°C

Relative Humidity = 60 to 70% RH

Air Pressure = 86 to 106kPa

3.3 Operating Temperature Range -55°C ~ +125°C

3.4 Storage Temperature Range -5°C ~ +40°C

3.5 Flammability Rating Tested in accordance to UL-94, V-0

3.6 Moisture Sensitivity Level Rating Level 1

3.7 ASJ resistors are RoHS compliance in accordance to RoHS Directive 2002/95/EC.

ASJ	LEAD FREE LOW RESISTANCE CHIP RESISTOR SPECIFICATION	REV: Q
	DOC NO: SYS-ENG-207	PAGE: 5 of 24

3.8 Resistance Range, Resistance Tolerance and Temperature Coefficient of Resistance.

Table 2 :

Type	Resistance Range and Tolerance						
	F (±1%)				J (±5%)		
CR10/CR12 (0402)	-	-	0.04≤R<0.10	0.10≤R<1.0	-	-	0.04≤R<1.0
CR16/CR18 (0603)	-	-	0.04≤R<0.10	0.10≤R<1.0	-	-	0.04≤R<1.0
CR21 (0805)	-	-	0.03≤R<0.10	0.10≤R<1.0	-	-	0.03≤R<1.0
CR32 (1206)	0.01≤R<0.03	0.01≤R<0.03	0.03≤R<0.10	0.10≤R<1.0	0.01≤R<0.03	0.01≤R<0.03	0.03≤R<1.0
CR40 (1210)	-	0.01≤R<0.03	0.03≤R<0.10	0.10≤R<1.0	-	0.01≤R<0.03	0.03≤R<1.0
CR50/CR52 (2010)	0.01≤R<0.03	0.01≤R<0.03	0.03≤R<0.10	0.10≤R<1.0	0.01≤R<0.03	0.01≤R<0.03	0.03≤R<1.0
CR63 (2512)	0.01≤R<0.03	0.01≤R<0.03	0.03≤R<0.10	0.10≤R<1.0	0.01≤R<0.03	0.01≤R<0.03	0.03≤R<1.0
Temperature Coefficient of Resistance (TCR)	±100ppm	± 1500ppm	± 200ppm (±100ppm/°C for 1210,2010 & 2512)	± 100ppm (±200ppm/° C for 0402 & 0603)	±100ppm	± 1500ppm	± 200ppm

* Contact factory for TCR information on values under 0.05 ohms

3.9 Rated Voltage

The rated voltage is calculated from the rated power and nominal resistance by the following formula:

$$E = \sqrt{P.R}$$

Where E : Rated Voltage (V)

P : Rated Power (W)

R : Nominal Resistance (Ω)

In case the value calculated by the formula exceeds the maximum working voltage given in Table 1, the maximum working voltage in Table 1 shall be regarded as the rated voltage.

ASJ	LEAD FREE LOW RESISTANCE CHIP RESISTOR SPECIFICATION	REV: Q
	DOC NO: SYS-ENG-207	PAGE: 6 of 24

4. MARKING ON PRODUCT

4.1 The nominal resistance shall be marked on the surface of each resistor.

Table 3 :

Type	Color	Marking on Product
CR10/CR12 (0402)	No Marking	1) Tolerance : +/-1.0% (F) • Four Numerals Marking (E96 Series) • 0603 Three Characters Marking based on E-96 marking standard. 2) Tolerance; ± 2.0% (G), ±5.0% (J), ±10% (K) Three Numerals Marking
CR16/CR18 (0603)	Light Brown	
CR21 (0805)	Light Brown	
CR32 (1206)	Light Brown	
CR40 (1210)	Light Brown	
CR50 (2010)	Light Brown	
CR52 (2010)	Light Brown	
CR63 (2512)	Light Brown	

5. COMPONENT DIMENSION, CONSTRUCTION AND MATERIAL

5.1. Dimension

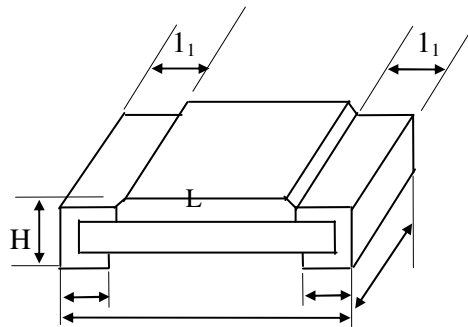

TYPE	L	W	H	I ₁	I ₂
CR10 / CR12 (0402)	0.040±0.004	0.020±0.002	0.014±0.002	0.008±0.004	0.010±0.004
	(1.00±0.10)	(0.50±0.05)	(0.35±0.05)	(0.20±0.10)	(0.25±0.10)
CR16 / CR18 (0603)	0.063±0.004	0.031±0.004	0.018±0.004	0.012±0.008	0.012±0.008
	(1.60±0.10)	(0.80±0.10)	(0.45±0.10)	(0.30±0.20)	(0.30±0.20)
CR21 (0805)	0.079±0.006	0.049±0.004	0.020±0.004	0.016±0.008	0.016±0.008
	(2.00±0.15)	(1.25±0.10)	(0.50±0.10)	(0.40±0.20)	(0.40±0.20)
CR32 (1206)	0.122±0.004	0.063±0.006	0.022±0.002	0.020±0.010	0.020±0.010
	(3.10±0.10)	(1.60±0.15)	(0.55±0.05)	(0.50±0.25)	(0.50±0.25)
CR40 (1210)	0.122±0.004	0.098±0.006	0.022±0.002	0.020±0.010	0.016±0.008
	(3.10±0.10)	(2.50±0.15)	(0.55±0.05)	(0.50±0.25)	(0.40±0.20)
CR50 / CR52 (2010)	0.200±0.006	0.098±0.006	0.022±0.002	0.024±0.010	0.016±0.008
	(5.00±0.15)	(2.50±0.15)	(0.55±0.05)	(0.60±0.25)	(0.40±0.20)
CR63 (2512)	0.250±0.006	0.126±0.006	0.022±0.002	0.024±0.010	0.016±0.008
	(6.30±0.15)	(3.20±0.15)	(0.55±0.05)	(0.60±0.25)	(0.40±0.20)

Unit of Measurement : Inches (Millimeters)

ASJ	LEAD FREE LOW RESISTANCE CHIP RESISTOR SPECIFICATION	REV: Q
	DOC NO: SYS-ENG-207	PAGE: 7 of 24

5.2 Construction

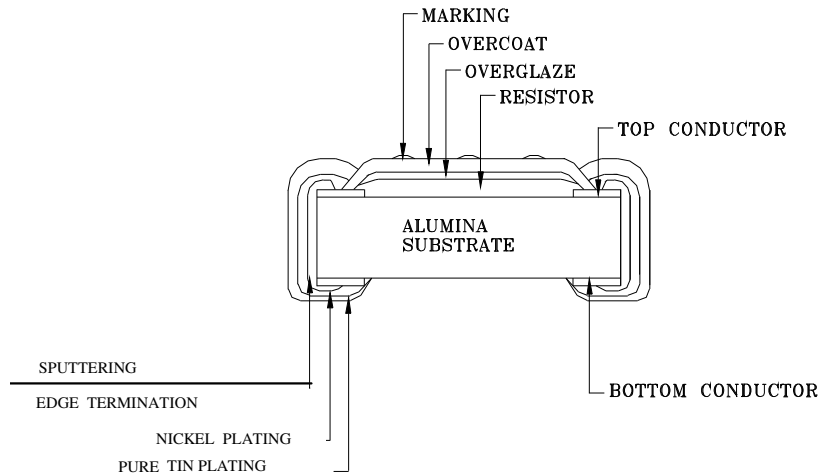

5.3 Material

Table 4:

<i>Construction</i>		<i>Material Used</i>	<i>Thickness</i>
Substrate	Ceramic Substrate	Alumina substrate, 96% purity	-
Resistive body	Resistor	Ruthenium oxide	-
Protective Film	Overglaze	Borosilicate-glass	-
	Overcoat	Epoxy Polymer	-
Internal Electrode	Top/ Bottom Conductor	Silver palladium	30± 2µm (Wet)
Secondary Electrode	Nickel Plating	Nickel	2.5 ~ 12 µm
Tertiary Electrode	Pure Tin Plating	Pure Tin	3.0 ~ 15 µm
Edge Terminal	Sputtering	Nickel Chromium	0.08 ~ 0.2 µm

ASJ	LEAD FREE LOW RESISTANCE CHIP RESISTOR SPECIFICATION	REV: Q
	DOC NO: SYS-ENG-207	PAGE: 8 of 24

6. ELECTRICAL CHARACTERISTICS AND TEST CONDITIONS

CHARACTERISTICS		SPECIFICATIONS	TESTING CONDITIONS														
		Resistance															
1	Resistance Value	Resistance accuracy being fully rely with respect to tolerance of resistor.	<p>JIS C 5202 5.1 Application time to be within 5 secs. Applied Voltage for resistance measurement :</p> <table border="1" style="width: 100%; border-collapse: collapse;"> <tr> <td style="padding: 2px;">$<10\Omega$</td> <td style="padding: 2px;">0.1V</td> </tr> <tr> <td style="padding: 2px;">10~99Ω</td> <td style="padding: 2px;">0.3V</td> </tr> <tr> <td style="padding: 2px;">100~999</td> <td style="padding: 2px;">1.0V</td> </tr> <tr> <td style="padding: 2px;">1K~ 9.9K</td> <td style="padding: 2px;">3.0 V</td> </tr> <tr> <td style="padding: 2px;">10K~ 99.9K</td> <td style="padding: 2px;">10.0 V</td> </tr> <tr> <td style="padding: 2px;">100K~999K</td> <td style="padding: 2px;">30.0 V</td> </tr> <tr> <td style="padding: 2px;">1M & Over</td> <td style="padding: 2px;">50.0 V</td> </tr> </table>	$<10\Omega$	0.1V	10~99 Ω	0.3V	100~999	1.0V	1K~ 9.9K	3.0 V	10K~ 99.9K	10.0 V	100K~999K	30.0 V	1M & Over	50.0 V
$<10\Omega$	0.1V																
10~99 Ω	0.3V																
100~999	1.0V																
1K~ 9.9K	3.0 V																
10K~ 99.9K	10.0 V																
100K~999K	30.0 V																
1M & Over	50.0 V																
2	Resistance Temperature of Coefficient	Refer Section 3.8 Table 2	<p>JIS C 5202 5.2 Measure R at $t_0=25^{\circ}\text{C}$ and after 45 minutes measure R at $t=125^{\circ}\text{C}$. Calculation : $\text{TCR}(\text{ppm}/^{\circ}\text{C}) = \frac{R - R_0}{R_0} \times \frac{1}{t - t_0} \times 10^6$</p>														
3	Voltage Coefficient (Applicable for $>1\text{K}\Omega$ only)	Voltage coefficient $\leq 100\text{ppm}/\text{V}$	<p>JIS C 5202 5.3 Method II Apply DC Voltage, $E_2=1/10$ rated voltage and $E_1=100\%$ rated voltage to Rx. Measure voltage V_1 & V_2 across Rs. Voltage applied shall be 3secs or less during 5secs of E_1 and not more than 10secs during E_2 Calculation : $V_c(\%/V) = \frac{(V_2 \times 10) - V_1}{V_1} \times \frac{1}{E_1 - E_2} \times 100$</p>														
4	Short Time Overload	$\pm(1\%)$ for 5% tolerance resistor $\pm(0.5\%)$ for 1% tolerance resistor	<p>JIS C 5202 5.5 Apply at 2.5 times rated voltage for 5 seconds. Applied voltage shall not exceed maximum overload voltage or current.</p>														

ASJ	LEAD FREE LOW RESISTANCE CHIP RESISTOR SPECIFICATION		REV: Q
	DOC NO: SYS-ENG-207		PAGE: 9 of 24

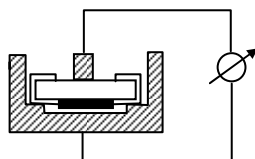
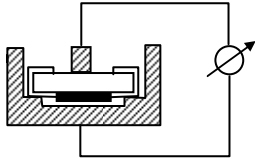
5	Insulation Resistance	$> 10G \Omega$		<p>JIS C 5202 5.6 Apply 500V \pm 15VDC for 1 minute</p> 
6	Dielectric Withstanding Voltage	No failure of resistor such as short-circuit, burning, breakdown.		<p>JIS C 5202 5.7 Apply 500VAC for 1 minute \pm 10secs.</p> 
		$\pm(1\%)$		
7	Intermittent Overload	$\pm(5\%)$		<p>JIS C 5202 5.8 Apply 4 times rated voltage for 1 sec ON and 25 secs OFF Total 10 000\pm 400 cycles Applied Voltage/Current shall not exceed maximum intermittent overload voltage/current. The sample shall be left at ambient temperature for 30 minutes before measurement.</p>
8	Noise	≤ 1	$<-10dB$ (0.32 μ v/v)	<p>JIS C 5202 5.9 $V_n(dB) = T-f(T-S)-D$</p>
9	Terminal Strength	With no evidence of mechanical damage after releasing the pressure.		<p>JIS C 5202 6.1</p> <p>JIS C5202 6.1.4(1)Method 2 Bend Test : Apply force till 3mm bend and hold for 10\pm1 sec. Measure resistance while applying pressure. Pull Test : Apply 0.5kgF for 30\pm5 secs</p> <p>JIS C5202 6.1.4(3)Method B Push Test : Apply 1.2kgF for 60\pm5secs</p>
	A) Bend Test (Applicable for chip size \leq 1210)	$\pm(1.0\%)$		
	B) Pull Test (Applicable for chip size \geq 0805)	$\pm(1.0\%)$		
	C) Push Test	$\pm(1.0\%)$		

ASJ	LEAD FREE LOW RESISTANCE CHIP RESISTOR SPECIFICATION	REV: Q
	DOC NO: SYS-ENG-207	PAGE: 10 of 24

10	Resistance to soldering heat	$\leq 50\text{m}\Omega$	$\pm(0.5\%)$ for 1% & 5% tolerance resistor	<p>JIS C 5202 6.10</p> <p>A) Solder bath method Resistor dipped entirely in solder bath of $260\pm 5^\circ\text{C}$ for 10_{-0}^{+1} sec.</p> <p>B) Flow soldering Preheat : 100°C to 105°C for 30 ± 5 sec. Resistor dipped entirely in solder bath of $265\pm 3^\circ\text{C}$ for 5_{-0}^{+1}</p> <p>C) Reflow soldering method Peak : $260_{-0}^{+5} \text{ }^\circ\text{C}$ $230\pm 5^\circ\text{C}$ for 30-40secs.</p> <p>D) Soldering Iron method Bit temp.: $350\pm 10^\circ\text{C}$ Application time of soldering iron is 3_{-0}^{+1} sec. After which the sample shall be left at ambient temperature for 1~ 2 hrs before measurement.</p>
11	Solderability	$\geq 95\%$ Coverage		<p>Precondition by baking 4 hours at 155°C.</p> <p>JIS C 5202 6.11</p> <p>Solder bath method : Solder : Sn-3Ag-0.5Cu Flux : 25% Colophony, 75% 2- Propanol by weight. $245\pm 5^\circ\text{C}$ for 2_{-0}^{+1} sec</p>
12	Resistance to Solvent	$\pm(1\%)$ Marking shall be legible without mechanical damage in appearance		<p>JIS C 5202 6.9</p> <p>Immerse in 20°C~25°C Isoproyl Alcohol solvent for 60 ± 10secs.</p>
13	Low Temperature	$\pm(0.5\%)$ for 1% tolerance resistor $\pm(1\%)$ for 5% tolerance resistor		<p>JIS C 5202 7.1</p> <p>$-55\pm 3^\circ\text{C}$ for $1000 \pm_{-0}^{+48}$ hours Sample shall be left at ambient temperature for 1~ 2 hrs after test before measuring final resistance.</p>

ASJ	LEAD FREE LOW RESISTANCE CHIP RESISTOR SPECIFICATION	REV: Q
	DOC NO: SYS-ENG-207	PAGE: 11 of 24

14	Low Temperature with Load	$\pm(0.5\%)$ for 1% tolerance resistor $\pm(1\%)$ for 5% tolerance resistor	JIS C 5202 7.1 -55 \pm 3°C for 90 minutes, 0.1 rated continuous working voltage as per 3.6 shall be applied for 45 \pm_0^5 minutes. Voltage Sample shall be left at ambient temperature for ~ 8 hrs after the removal of the voltage for 15 \pm_0^5 before measuring final resistance.
15	High Temperature	$\pm(1\%)$ for 1% tolerance resistor $\pm(2\%)$ for 5% tolerance resistor	JIS C 5202 7.2 125 \pm 5°C for 1000 \pm_0^{48} hours Sample shall be left at ambient temperature for 1~ 2 hrs after test before measuring final resistance.
16	Thermal Shock (Temperature Cycling)	$\pm(0.5\%)$ for 1% tolerance resistor $\pm(1\%)$ for 5% tolerance resistor	JIS C 5202 7.4 <i>Step Temp. Time</i> (°C) (Minute) 1 -55 \pm 5 30 mins 2 25 \pm 5 5 mins max 3 155 \pm 5 30 mins 4 25 \pm 5 5 mins max Repeat step 1 to 4 for 5 cycles
17	Resistance to damp Heat (Humidity)	$\pm(0.5\%)$ for 1% tolerance resistor $\pm(2.0\%)$ for 5% tolerance resistor	JIS C 5202 7.5 40 \pm 2°C and 90~95%RH for 1000 \pm_0^{48} hours. Sample shall be left at ambient temperature for 1~ 2 hrs after test before measuring final resistance.
18	Loadlife	$\pm(1.0\%)$ for 1% tolerance resistor $\pm(2.0\%)$ for 5% tolerance resistor	JIS C 5202 7.10 At 70 \pm 3°C Apply DC rated voltage at 90minutes On, 30minutes Off for 1000 \pm_0^{48} Hours. Sample shall be left at ambient temperature for 1~ 2 hrs after test before measuring final resistance.
19	Salt Spray	$\pm(3\%)$	JIS C 5202 7.7 Spray 5 \pm 1 Wt% salt water for 96 \pm 4 hours at 35 \pm 2°C

ASJ	LEAD FREE LOW RESISTANCE CHIP RESISTOR SPECIFICATION	REV: Q
	DOC NO: SYS-ENG-207	PAGE: 12 of 24

6.1 Soldering Profile

6.1.1 Flow Soldering

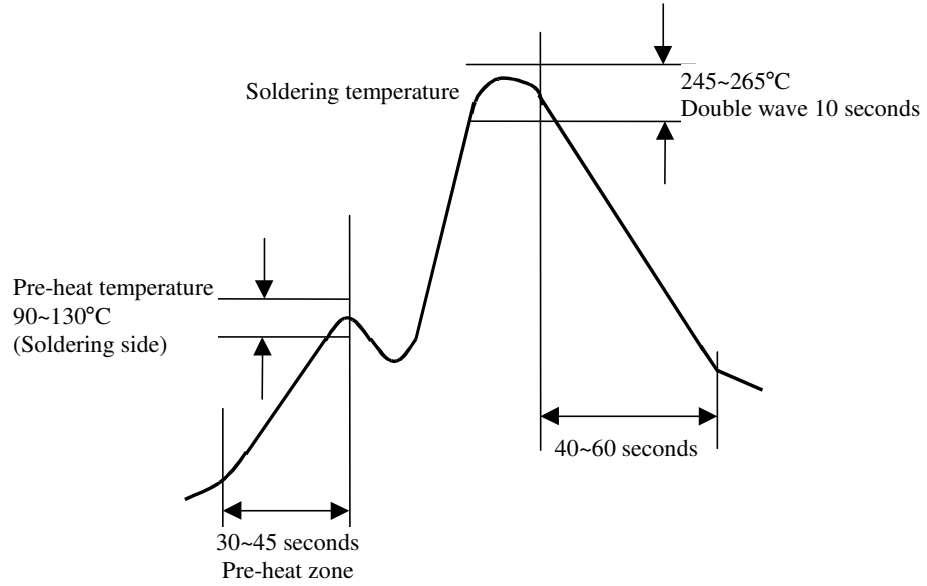

6.1.2 Reflow Soldering

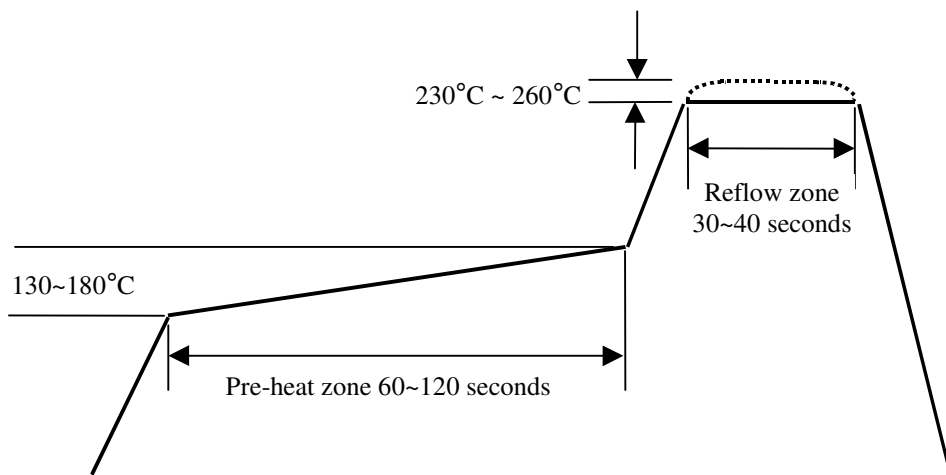

ASJ	LEAD FREE LOW RESISTANCE CHIP RESISTOR SPECIFICATION	REV: Q
	DOC NO: SYS-ENG-207	PAGE: 13 of 24

7 TAPING

7.1 Structure of Taping

Taping of Rectangularly Punched Carrier System

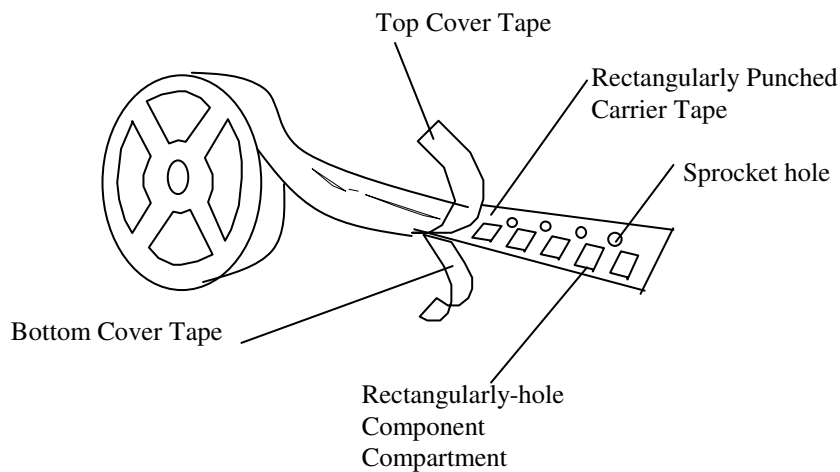

7.2 Material

- (1) Every taping shall consist of materials as shown in Table 5.
- (2) Every taping shall not adversely affect the mechanical, electrical and solderability performances.
- (3) Materials of taping shall generate no static.
The taped products are stored at a temperature -5 to +40°C and a relative humidity
- (4) 40 to 60% without exposing to direct sunlight and, after such conditioning, the tape shall show no deterioration in performances such as change in adhesion force or peel forces.

Table 5:

Type	Carrier Tape	Top Cover Tape	Bottom Cover Tape
Taping of Rectangularly Punched Carrier System	Paper	Thermal adhesion Polyester	Thermal adhesion paper

ASJ	LEAD FREE LOW RESISTANCE CHIP RESISTOR SPECIFICATION	REV: Q
	DOC NO: SYS-ENG-207	PAGE: 14 of 24

7.3 Leader and Trailer Tape

- 1) Leader Tape The length of leader tape shall be at least 500 mm including 40 or more or rectangular holes (component compartments) in which no component is placed.

The 40 or more empty component compartments shall be sealed with the top cover tape (see Fig. 2).

- 2) Trailer Tape The trailer tape at the hub of reel shall be least 40 mm in length including carrier tape with empty component compartments. The empty component compartments shall be sealed with the top cover tape.

The last portion of the carrier tape shall release from the reel hub.

Fig. 2 Explanation of Leader and Trailer Tape

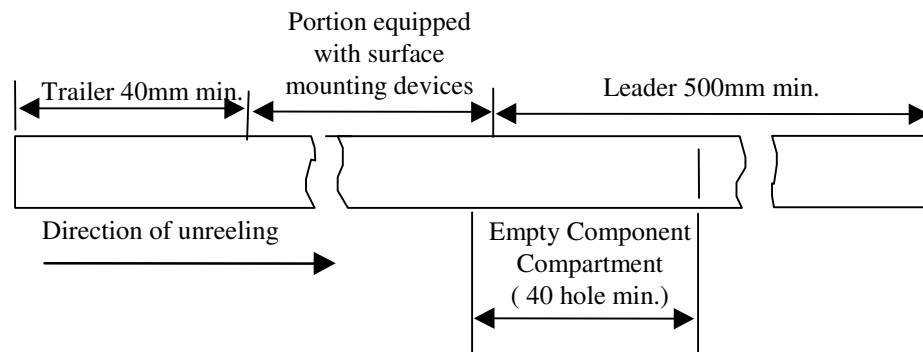

- 7.4 Position of Taped Component The angle made by the center line of taped component and the center line of component compartment shall not exceed 20 degrees (see Fig. 3).

Fig. 3 Angle between Center Line of Component and Center Line of Component compartment

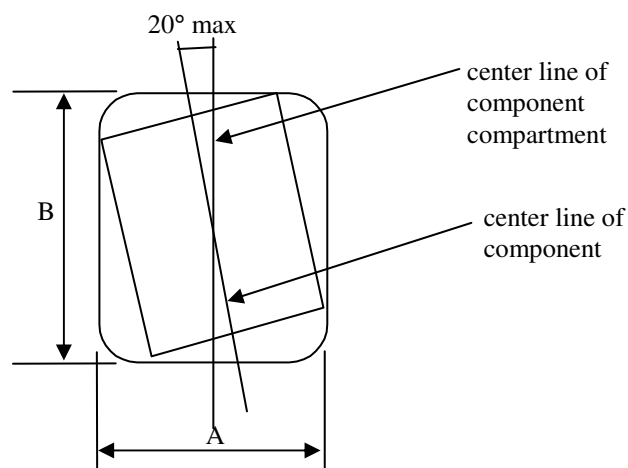

7.5 Tape Dimension

7.5.1 Paper tape (For 0402)

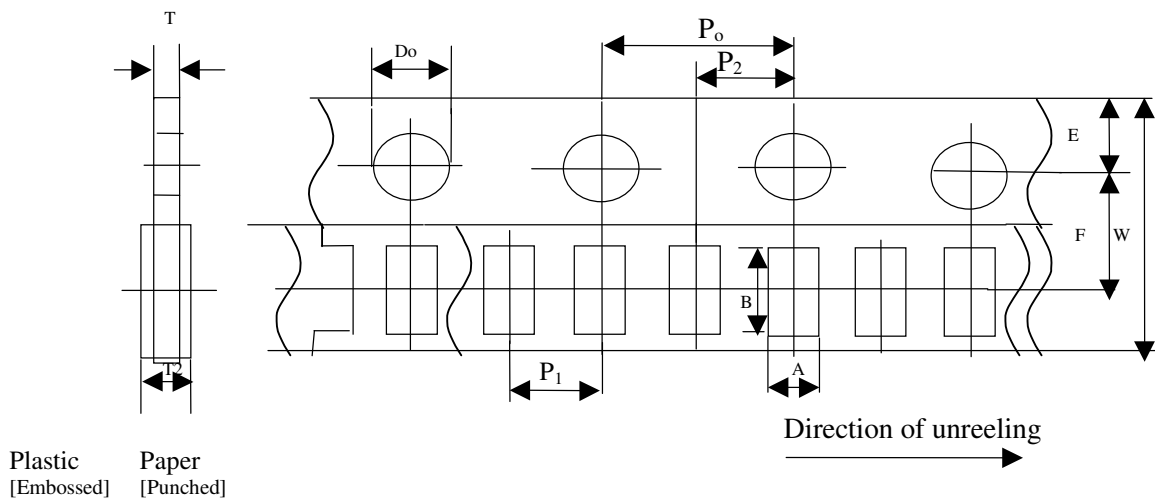

Remark : Pitch tolerance over any 10 pitches of P_0 is ± 0.2 mm

Dimension of Punched Paper Tape Carrier System (CR10)

(unit : mm)

Code	A	B	W	E	F	P_1
CR10/12	0.65 ± 0.1	1.15 ± 0.1	8.0 ± 0.2	1.75 ± 0.1	3.5 ± 0.05	2.0 ± 0.5

Code	P_2	P_0	D_0	T_2	T	
CR10/12	2.0 ± 0.05	4.0 ± 0.1	$1.5 \pm^{0.1}$	1.0 max	--	

7.5.2 Paper Tape (For 0603, 0805, 1206, 1210 only)

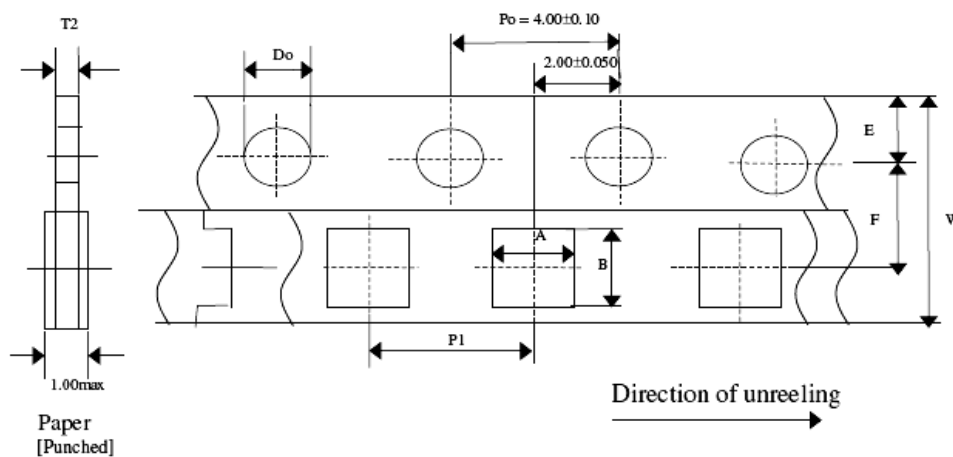

Remark: Pitch tolerance over any 10 pitches of P_0 is ± 0.20 mm

ASJ	LEAD FREE LOW RESISTANCE CHIP RESISTOR SPECIFICATION	REV: Q
	DOC NO: SYS-ENG-207	PAGE: 16 of 24

Type	A	B	W	E	F	P1	Do	T2
CR16/18 (0603)	1.10 ± 0.10	1.90 ± 0.10	8.00 ± 0.20	1.75 ± 0.10	3.50 ± 0.05	4.00 ± 0.10	1.50 ± 0 ^{0.10}	0.60 ± 0.10
CR21 (0805)	1.65 ± 0.10	2.40 ± 0.10						0.75 ± 0.10
CR 32 (1206)	1.90 ± 0.10	3.50 ± 0.10						0.75 ± 0.10
CR 40 (1210)	2.80 ± 0.10	3.50 ± 0.10						0.75 ± 0.10

Unit of Measurement: mm

7.5.3 Embossed Tape (For 2010 & 2512 only)

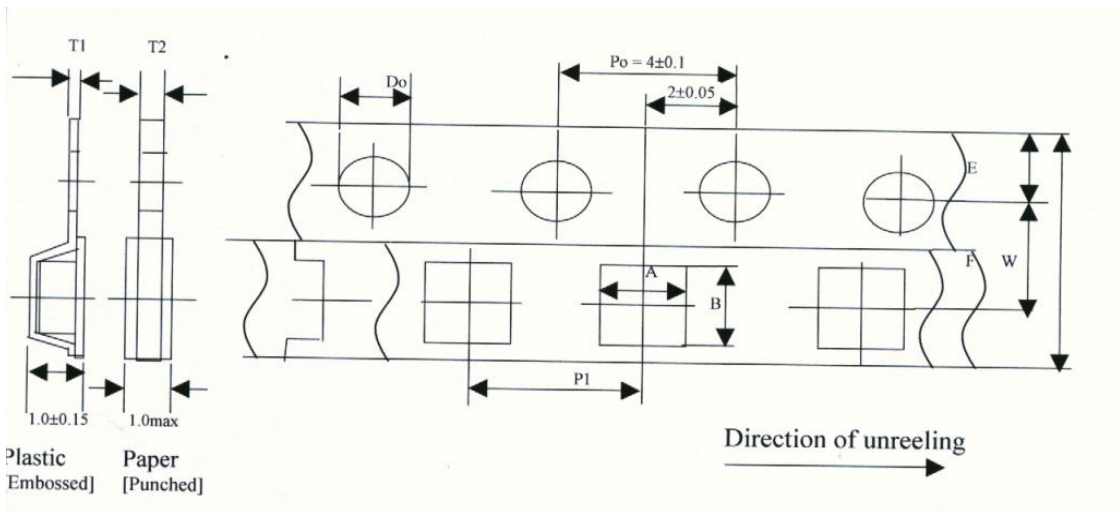

Remark : Pitch tolerance over any 10 pitches of Po is ±0.20mm

Type	A	B	W	E	F	P1	Do	T1
CR50/52 (2010)	2.90 ± 0.20	5.40 ± 0.20	12.00 ± 0.10	1.75 ± 0.10	5.50 ± 0.05	4.00 ± 0.10	1.50 ± 0 ^{0.10}	0.20 ± 0.10
CR63 (2512)	3.60 ± 0.20	6.60 ± 0.10						

Unit of Measurement : mm

ASJ	LEAD FREE LOW RESISTANCE CHIP RESISTOR SPECIFICATION	REV: Q
	DOC NO: SYS-ENG-207	PAGE: 17 of 24

7.6 Performance of Taping

7.6.1 Strength of carrier tape and top cover tape

When a tensile force of 10N (1.02 kgf) is applied in the direction of unreeling the tape, the carrier tape and top cover tape shall withstand this force.

7.6.2 Peel force of top cover tape

- a) Ensure that the peel force meter is reset to ϕ initially.
- b) A minimum of 4 holes is required when the top cover tape is pulled.
- c) Do not reset the peel force meter.
- d) The peel force of top cover tape shall be 0.1N to 0.7N (10 to 70 gf) when the top cover tape is pulled at a speed of 300 mm/min with the angle between the tape during peel and the direction of unreeling maintained at 165 to 180 degree as illustrated in Fig 4.

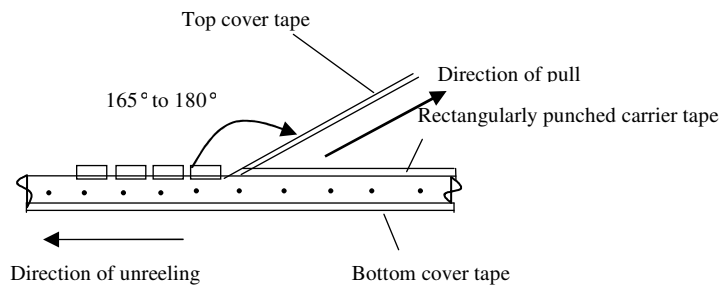

Fig. 4 Peeling Test

7.6.3 Minimum Bending Radius

When the tape is bent with the minimum bending radius specified in Fig 5 and Table 6, components shall maintain their position and shall be free from abnormalities such as damage.

Table 6:

Width of Tape	Minimum Bending Radius
8 mm	30 mm
12 mm	30 mm

Fig. 5 Explanation of Minimum Bending Radius

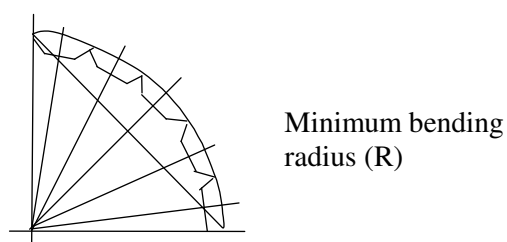

ASJ	LEAD FREE LOW RESISTANCE CHIP RESISTOR SPECIFICATION	REV: Q
	DOC NO: SYS-ENG-207	PAGE: 18 of 24

7.7 Packaging

7.7.1 Standard Packaging Pan Size

7.7.1.1 Quantity – Tape and Reel

Type	Quantity	Remarks
CR10/CR12 (0402)	10000 pcs	-
CR16/ CR18 (0603)	5000 pcs	10 000 or 20 000 pcs on request
CR21 (0805)	5000 pcs	
CR32 (1206)	5000 pcs	
CR40 (1210)	5000 pcs	-
CR50/CR52 (2010)	4000 pcs	-
CR63 (2512)	4000 pcs	-

7.7.2 Identification

A label indicating product type, resistance value and tolerance shall be pasted on the surface of each reel. Customer part number and purchase order number will be included when required.

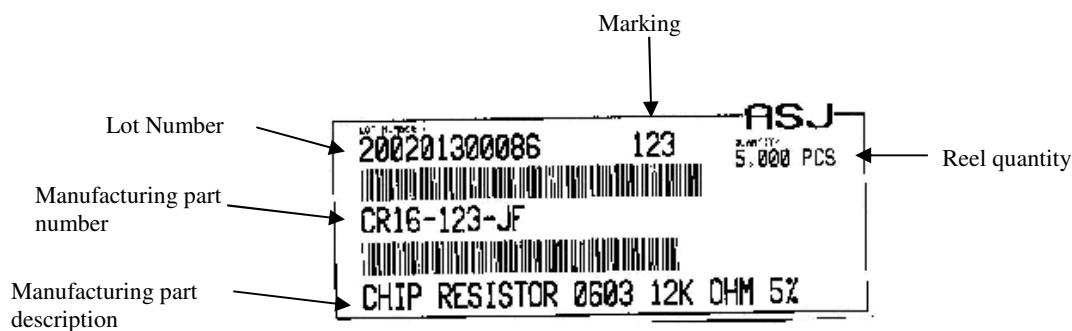

How to read lot Number:

XXXX	XX	XX	XXXX
Year	Mth	Day	Serialize Number

ASJ	LEAD FREE LOW RESISTANCE CHIP RESISTOR SPECIFICATION	REV: Q
	DOC NO: SYS-ENG-207	PAGE: 20 of 24

7.7.4 Reel Dimension

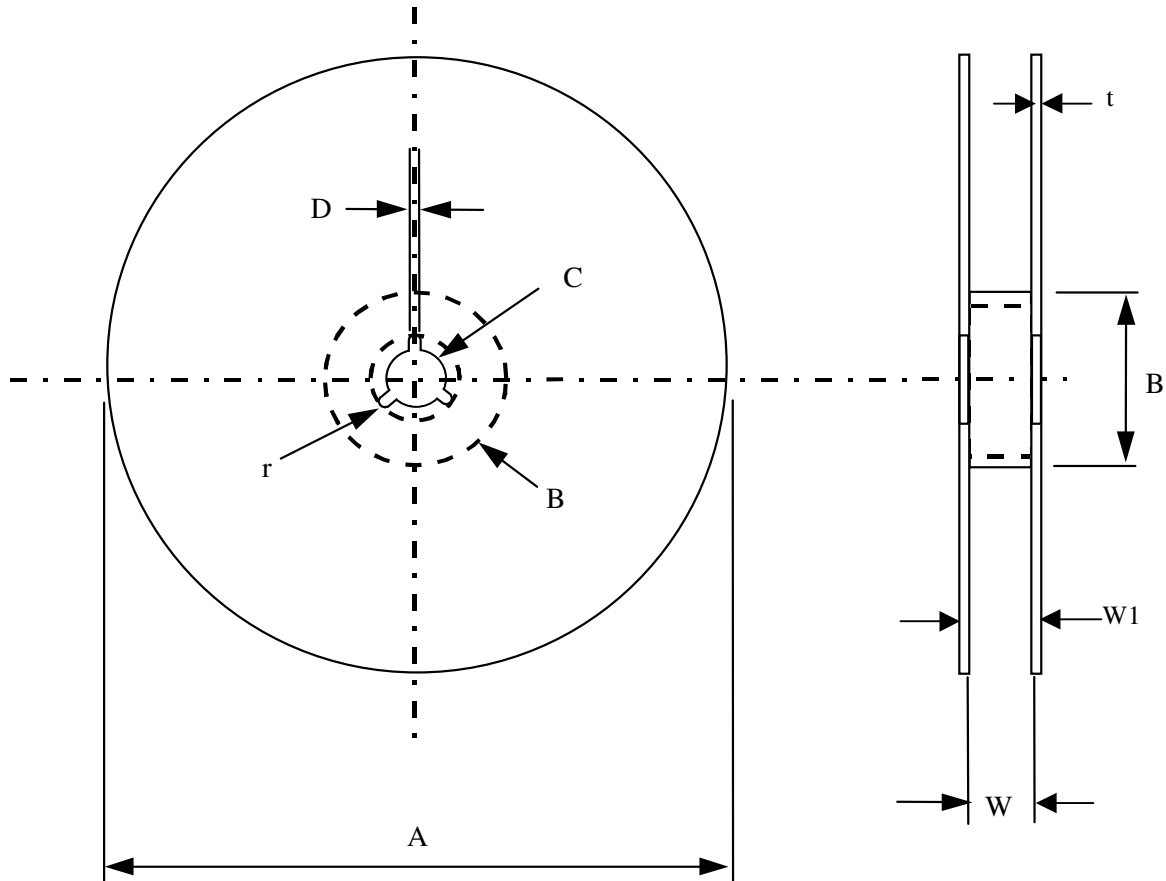

Model	A	B	C	D	W	W ₁	t	r
7"Reel (5K)	$\phi 178 \pm 2.0$	$\phi 60 \pm 0.1$	13 ± 0.2	2.0 ± 0.5	11 ± 1.0	14.4 max	1.0 ± 0.1	1.0
7"Reel (4K)	$\phi 178 \pm 2.0$	$\phi 60 \pm 0.1$	13 ± 0.2	2.0 ± 0.5	13 ± 1.0	14.4 max	1.2 ± 0.1	1.0
10"Reel (10K)	$\phi 254 \pm 2.0$	$\phi 60 \pm 0.1$	13 ± 0.2	2.0 ± 0.5	11 ± 1.0	14.4 max	1.5 ± 0.1	1.0
13"Reel (20K)	$\phi 330 \pm 2.0$	$\phi 60 \pm 0.1$	13 ± 0.2	2.0 ± 0.5	11 ± 1.0	14.4 max	2.1 ± 0.1	-

ASJ	LEAD FREE LOW RESISTANCE CHIP RESISTOR SPECIFICATION	REV: Q
	DOC NO: SYS-ENG-207	PAGE: 21 of 24

8 Surface Mount Land Patterns

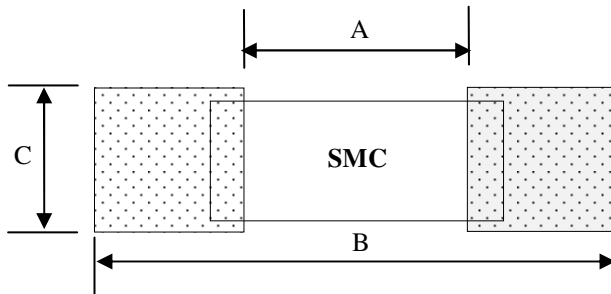

Product (Type)	Land Dimension		
	A	B	C
CR10/ CR12 (0402)	0.020 [0.5]	0.059 [1.5]	0.020 ~ 0.024 [0.5 ~ 0.6]
CR16 / CR18 (0603)	0.039 [1.0]	0.106 [2.7]	0.020 ~ 0.035 [0.5 ~ 0.9]
CR21 (0805)	0.043 [1.1]	0.138 [3.5]	0.043 ~ 0.051 [1.1 ~ 1.3]
CR32 (1206)	0.087 [2.2]	0.197 [5.0]	0.055 ~ 0.071 [1.4~1.8]
CR40 (1210)	0.087 [2.2]	0.197 [5.0]	0.083 ~ 0.118 [2.1 ~ 3.0]
CR50/CR52 (2010)	0.15 [3.8]	0.331 [8.4]	0.083 ~ 0.118 [2.1 ~ 3.0]
CR63 (2512)	0.189 [4.8]	0.413 [10.5]	0.098 ~ 0.189 [2.5 ~ 4.8]

8.1 Test board for 4 Wire CR10/CR12, CR16/CR18, CR21

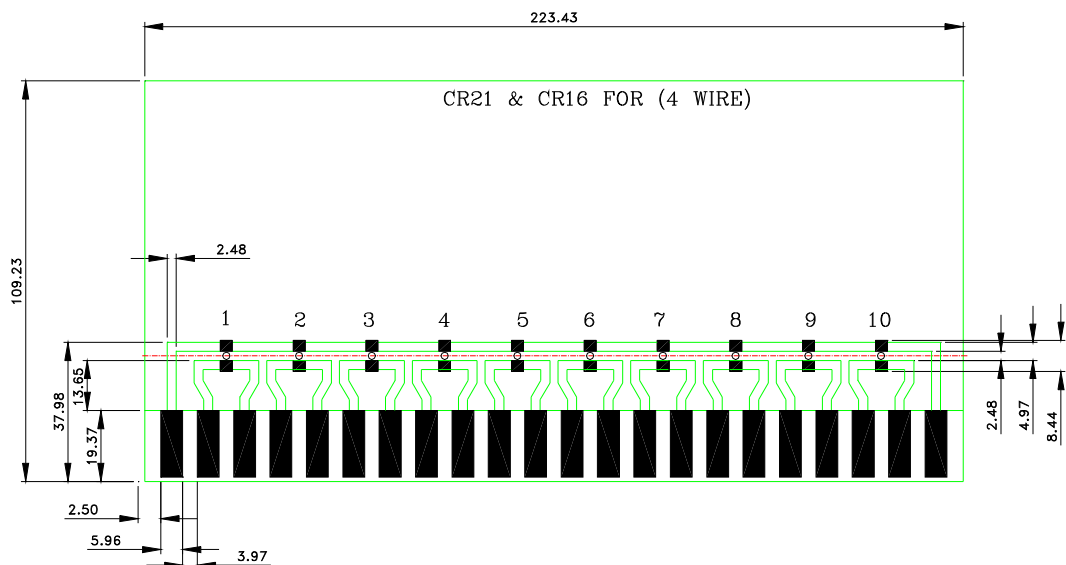

ASJ	LEAD FREE LOW RESISTANCE CHIP RESISTOR SPECIFICATION	REV: Q
	DOC NO: SYS-ENG-207	PAGE: 22 of 24

8.2 Test board for 4 Wire CR32 & CR40

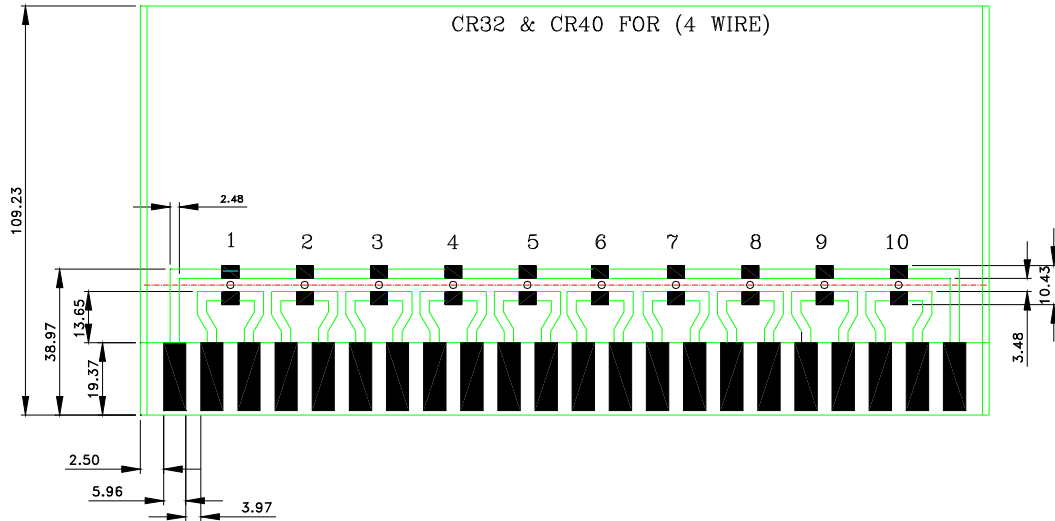

8.3 Test board for 4 Wire CR50/52 & CR63

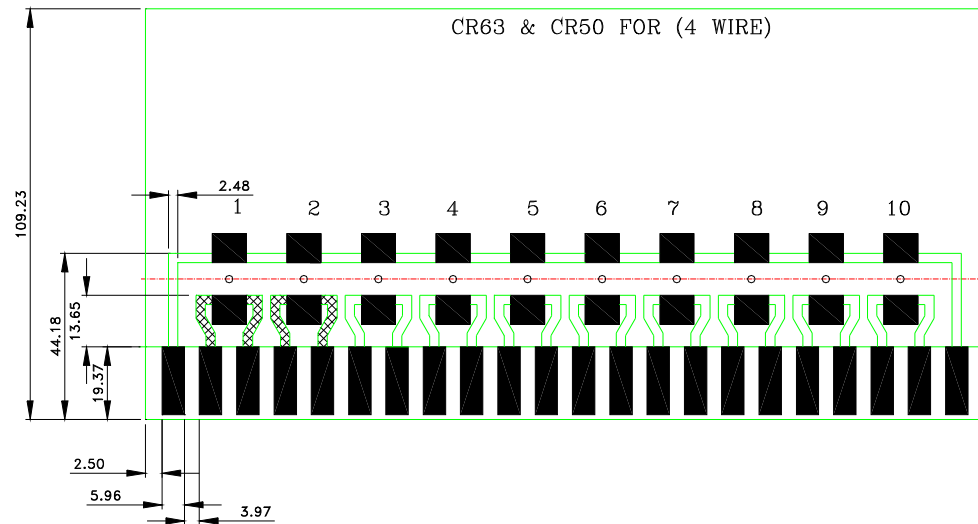

ASJ	LEAD FREE LOW RESISTANCE CHIP RESISTOR SPECIFICATION	REV: Q
	DOC NO: SYS-ENG-207	PAGE: 23 of 24

8.4 Test board for Bending Strength Test

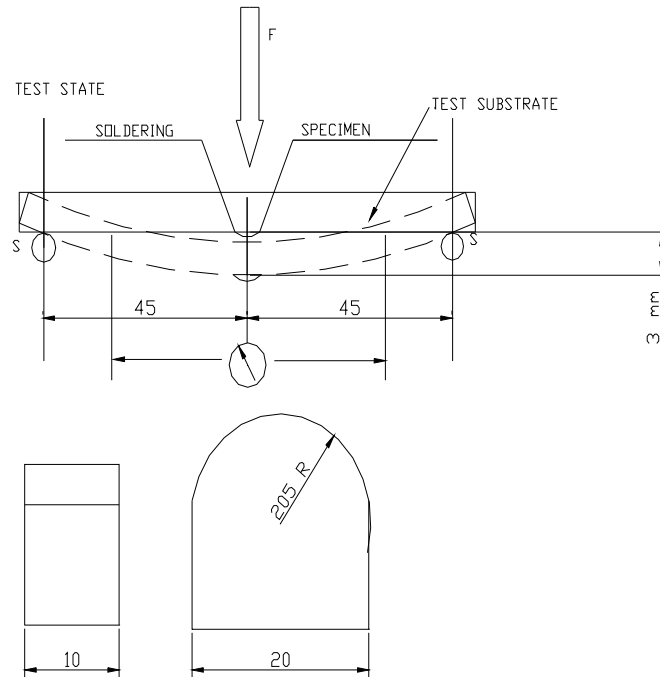

8.5 Insulating Resistance and Withstanding Voltage Test Fixture

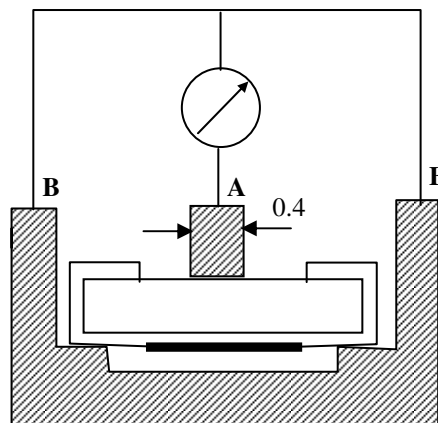

Remarks:

- Apply the test voltage between metal block, measuring point A (positive polarity) and metal plate measuring point B, and carry out the measurement between electrodes, and the insulating enclosure of the specimen.
- Centre clamp shall be equal-distance from the two side clamps.

ASJ	LEAD FREE LOW RESISTANCE CHIP RESISTOR SPECIFICATION	REV: Q
	DOC NO: SYS-ENG-207	PAGE: 24 of 24

9 APPLICABLE STANDARDS

JIS C 5202	Test Methods of Fixed Resistors for Electronic Equipment.
JIS C 5223	Fixed Thick Film Chip Resistors, Rectangular Type for Use in Electronic Equipment.
JIS C 0806	Packaging of Electronic Components on continuous tapes (surface mount devices).
MIL-R-55342	Resistors, Fixed, Film, Chip, Established Reliability, General Specifications for.
MIL-STD-202	Test Methods for Electronic and Electrical Parts .
IPC/JEDEC J STD 020B	Moisture / Reflow sensitivity classification for non hermetic solid state surface mount devices.
2002/95/EC	RoHS Directive.