



ASJ PTE LTD

**LEAD FREE CHIP RESISTOR
NETWORK SPECIFICATION - CONCAVE**

Reference No. : SYS-ENG-208

Revision No. : D

--



1.0	SCOPE.....	3
2.0	PART NUMBERING SYSTEM.....	3
3.0	RATING.....	3
3.1	Rating Power.....	3
3.2	Operating Temperature Range.....	4
3.3	Storage Temperature Range.....	4
3.4	Flammability Rating	4
3.5	Moisture Sensitivity Rating Level	4
3.6	RoHS compliance	4
3.7	Resistance Range, Resistance Tolerance and Temperature Coefficient of Resistance	4
3.8	Rated Voltage.....	4
4.0	MARKING ON PRODUCT.....	4
5.0	COMPONENT DIMENSION	6
5.1	Dimension	6
5.2	Schematic	6
6.0	ELECTRICAL CHARACTERISTICS AND TEST CONDITIONS.....	7 – 10
6.1	Flow Soldering	11
6.2	Reflow Soldering	11
7.0	TAPING.....	12
7.1	Structure of Taping.....	12
7.2	Materials.....	12
7.3	Leader and Trailer Tape.....	13
7.4	Position of Taped Component.....	14
7.5	Tape Dimension.....	14
7.5.1	Paper Tape	14
7.6	Performance of Taping.....	15
7.6.1	Strength of carrier tape and top cover tape	15
7.6.2	Peel force of top cover tape	15
7.6.3	Minimum Bending Radius	15
7.7	Packaging.....	16
7.7.1	Standard Packaging Pan Size	16
7.7.2	Identification	16
7.7.3	Reel Dimension.....	17
8.0	SOLDER LAND PATTERN.....	18
9.0	APPLICABLE STANDARDS.....	18

ASJ	TITLE: LEAD FREE CHIP RESISTOR NETWORK SPECIFICATION - CONCAVE	REV: D
	DOC NO: SYS-ENG-208	PAGE: 3 of 18

1.0 SCOPE

This specification specified thick film chip resistor network used in high density SMD mounting for higher productivity with reduced assembling cost. In case there are discrepancies in specifications between this specification and the customer's specifications, the latter shall precede.

2.0 PART NUMBERING SYSTEM

Part Numbering is made in accordance with the following system:

<u>TCN</u>	<u>XX</u>	<u>X</u>	-	<u>XXXX</u>	-	<u>X</u>	<u>X</u>
Resistor Network	Type	No.of Resistor		Resistance Value Code		Tolerance	Packaging
TCN-Concave	10 or 16	4		See clause 4.0		F - $\pm 1\%$ G - $\pm 2\%$ J - $\pm 5\%$ Z - Zero ohm	L - 5K K - 10K Y - 20K

3.0 RATING

3.1 Rated Power

Table 1

(a) Zero Ohm Jumper Rated Power

Type	Rated Current	Dielectric Withstanding Voltage	Resistance Tolerance
TCN10	1A	300V	< 50 m Ω
TCN16	1A	300V	< 50 m Ω

(b) Resistor Rated Power

Type	Rated Power	Max. Working Voltage	Max.Overload Voltage
TCN10	1/16W	25V	50V
TCN16	1/10W	50V	100V

Rated Power shall be the load power corresponding to nominal wattage suitable for continuous use at 70°C ambient temperature. In case the ambient temperature exceeds 70°C, reduce the load power in accordance with Derating curve in Fig. 1.

Fig.1 Power Derating Characteristics

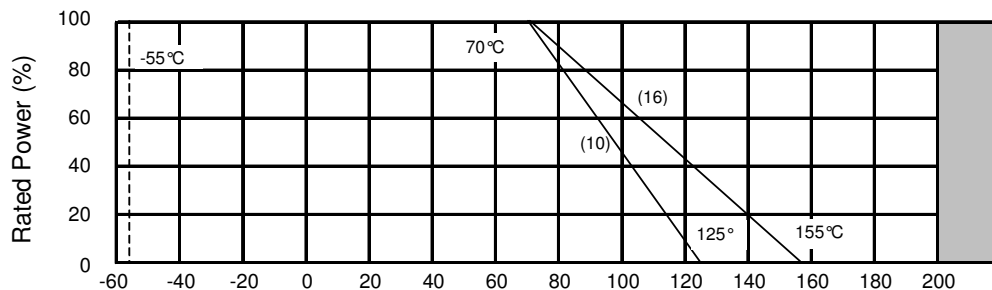

ASJ	TITLE: LEAD FREE CHIP RESISTOR NETWORK SPECIFICATION - CONCAVE	REV: D
	DOC NO: SYS-ENG-208	PAGE: 4 of 18

- 3.2 Operating Temperature Range : -55°C ~+125°C
- 3.3 Storage Temperature Range : -5°C ~+40°C
- 3.4 Flammability Rating : Tested in accordance to UL94, V-0
- 3.5 Moisture Sensitivity Level Rating : Level 1
- 3.6 ASJ resistors are RoHS complaint in accordance to RoHS Directive 2002/95/EC.
- 3.7 Resistance Range, Resistance Tolerance and Temperature Coefficient of Resistance.

Table 2

Product	No. of Resistor	Resistance Range	Temperature Coefficient of Resistance	Resistance Tolerance
TCN 10	4	10Ω to 1MΩ	±250ppm/°C	±1% & ±2%
		10Ω to 1MΩ	±200ppm/°C	±5%
TCN 16	4	1Ω to 1MΩ	±200ppm/°C	±1%, ±2% & 5%
Zero Ohm Jumper		< 0.05Ω		

3.8 Rated Voltage

The rated voltage is calculated from the rated power and nominal resistance by the following formula:

$$E = \sqrt{P.R.}$$

Where E : Rated Voltage (V)

P : Rated Power (W)

R : Nominal Resistance (Ω)

In case the value calculated by the formula exceeds the maximum working voltage given in Table 1, the maximum working voltage in Table 1 shall be regarded as the rated voltage.

4.0 MARKING ON PRODUCT

The nominal resistance shall be marked on the surface of each resistor.

Table 3 Marking on product

Part Number	Color	Marking
TCN10 TCN16	Light Brown	① Tolerance : ±1.0% (F) Marking by four numerals ② Tolerance: ±2.0% (G), ±5.0% (J) Marking by three numerals ③ Chip jumper resistor The marking used shall be 0

ASJ	TITLE: LEAD FREE CHIP RESISTOR NETWORK SPECIFICATION - CONCAVE	REV: D
	DOC NO: SYS-ENG-208	PAGE: 5 of 18

4.1 Numeric Numbering

4.1.1 2% & 5% Tolerance : *Three Numerals Marking Standard*

First 2 digits are significant figures, third digit is number of zeros. Letter R is decimal point.

Example :

<i>Nominal Resistance</i>	<i>Marking</i>	<i>Remarks</i>
1 Ω	1R0	$1 \times 10^0 = 1$
10 Ω	100	$10 \times 10^0 = 10$
100 Ω	101	$10 \times 10^1 = 100$
4.7K Ω	472	$47 \times 10^2 = 4700$
47K Ω	473	$47 \times 10^3 = 47000$
470K Ω	474	$47 \times 10^4 = 470000$
4.7M Ω	475	$47 \times 10^5 = 4700000$

4.1.2 0.5% & 1% Tolerance : *Four Numerals Marking Standard*

First 3 digits are significant figures, fourth digit is number of zeros.

Example :

<i>Nominal Resistance</i>	<i>Marking</i>	<i>Remarks</i>
1 Ω	1R00	$1 \times 10^0 = 1$
10 Ω	10R0	$10 \times 10^0 = 10$
100 Ω	1000	$100 \times 10^0 = 100$
4.7K Ω	4701	$470 \times 10^1 = 4700$
47K Ω	4702	$470 \times 10^2 = 47000$
470K Ω	4703	$470 \times 10^3 = 470000$
1M Ω	1004	$100 \times 10^4 = 1000000$

5.0 COMPONENT DIMENSION

5.1 Dimension

TCN TYPE (CONCAVE)

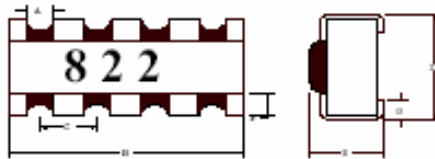

Type	Number of resistor	A	B	C	D	E	F	G
TCN10	4	0.30±0.10	2.00±0.10	0.50±0.10	1.00±0.10	0.40±0.10	0.15±0.10	0.25±0.10
TCN16	4	0.50±0.10	3.20±0.20	0.80±0.10	1.60±0.10	0.55±0.10	0.35±0.10	0.45±0.10

Unit of Measurement : mm

5.2 Schematic

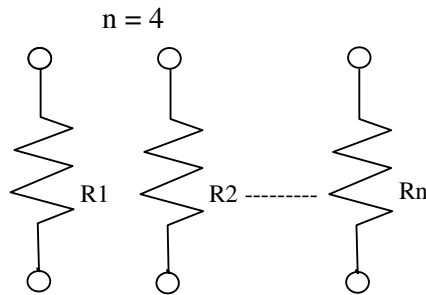

6.0 ELECTRICAL CHARACTERISTICS AND TEST CONDITIONS

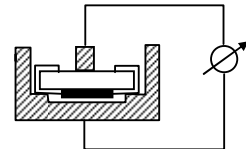
CHARACTERISTICS		SPECIFICATIONS		TESTING CONDITIONS														
		Zero Ohm	Resistance															
1	Resistance Value	≤ 50 mΩ	Resistance accuracy being fully rely with respect to tolerance of resistor.	JIS C 5202 5.1 Application time to be within 5 secs . Applied Voltage for resistance measurement :														
				<table border="1"> <tr> <td><10Ω</td> <td>0.1V</td> </tr> <tr> <td>10~99Ω</td> <td>0.3V</td> </tr> <tr> <td>100~999</td> <td>1.0V</td> </tr> <tr> <td>1K~ 9.9K</td> <td>3.0 V</td> </tr> <tr> <td>10K~</td> <td>10.0 V</td> </tr> <tr> <td>99.9K</td> <td>30.0 V</td> </tr> <tr> <td>100K~99</td> <td>50.0 V</td> </tr> <tr> <td>9K</td> <td></td> </tr> <tr> <td>1M & Over</td> <td></td> </tr> </table>	<10Ω	0.1V	10~99Ω	0.3V	100~999	1.0V	1K~ 9.9K	3.0 V	10K~	10.0 V	99.9K	30.0 V	100K~99	50.0 V
<10Ω	0.1V																	
10~99Ω	0.3V																	
100~999	1.0V																	
1K~ 9.9K	3.0 V																	
10K~	10.0 V																	
99.9K	30.0 V																	
100K~99	50.0 V																	
9K																		
1M & Over																		
2	Resistance Temperature Coefficient	NA	Refer Section 3.6 Table 2	JIS C 5202 5.2 Measure R at t ₀ =25 ⁰ C and after 45 minutes measure R at t=125 ⁰ C. Calculation : $TCR(ppm/^0C)=\frac{R-R_0}{R_0} * \frac{1}{t-t_0} * 10^6$														
3	Short Time Overload	≤ 50 mΩ	±(1%+0.05Ω)	JIS C 5202 5.5 Apply at 2.5 times rated voltage for 5 seconds. Applied voltage shall not exceed maximum overload voltage or current.														
4	Insulation Resistance	> 10G Ω		JIS C 5202 5.6 Apply 100V ± 15VDC for 1 minutes 														

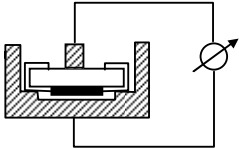
5	Dielectric Withstanding Voltage	No failure of resistor such as short-circuit, burning, breakdown.		<p>JIS C 5202 5.7 Apply 300VAC for 1 minutes \pm 10secs.</p> 	
		$\leq 50 \text{ m}\Omega$	$\pm(1\%+0.05\Omega)$		
6	Noise	NA	1~9 Ω	<-10dB (0.32 $\mu\text{v/v}$)	<p>JIS C 5202 5.9 $V_n(\text{dB}) = T - f(T-S) - D$</p>
			10~99 Ω	<-5dB (0.52 $\mu\text{v/v}$)	
			100~999 Ω	<0dB (1.0 $\mu\text{v/v}$)	
			1K~9.9K Ω	<10dB (3.2 $\mu\text{v/v}$)	
			10K~99.9K Ω	<18dB (5.6 $\mu\text{v/v}$)	
			100K~999.9K Ω	<20dB (10 $\mu\text{v/v}$)	
			>1M Ω	<30dB (32 $\mu\text{v/v}$)	
7	Terminal Strength - Bend Test	$\leq 50\text{m}\Omega$	<p>Tolerance resistor. With no evidence of mechanical damage after releasing the pressure. $\pm(1\%+0.05\Omega)$</p>		<p>JIS C 5202 6.1.4(1) Method 2 Apply force till 3mm bend and hold for 30 ± 1sec. Measure resistance while applying pressure.</p>
8	Resistance to soldering heat	$\leq 50\text{m}\Omega$	<p>$\pm(1\%+0.05\Omega)$</p>		<p>JIS C 5202 6.10 A) Solder bath method Preheat : 120 ± 10 °C for 40 secs. Resistor dipped entirely in solder bath of 260 ± 5°C for 10 ± 1sec. B) Reflow soldering method Peak : 250^{+5}_0 °C 230 ± 5°C for 30 - 40sec. C) Soldering Iron method Bit temp.: 350 ± 10°C Application time of soldering iron is 3 ± 1 sec. After which the sample shall be left at ambient temperature for 1~ 2 hrs before measurement.</p>



9	Solderability	$\geq 95\%$ Coverage		Precondition by baking 4 hours at 155°C. JIS C 5202 6.11 Solder bath method : Solder : Sn-3Ag-0.5Cu Flux : 25% Colophony, 75% 2-Propanol by weight. 245±5°C for 2 ₋₀ ⁺¹ sec
10	Resistance to Solvent	$\leq 50\text{m}\Omega$	$\pm(1\%+0.05\Omega)$ Marking shall be legible without mechanical damage in appearance.	JIS C 5202 6.9 Immerse in 20°C~25°C Isoproyl Alcohol solvent for 60±10secs.
11	Low Temperature	$\leq 50\text{m}\Omega$	$\pm(1\%+0.05\Omega)$	JIS C 5202 7.1 -55±5°C for 1000 ± ₀ ⁴⁸ hours Sample shall be left at ambient temperature for 1~ 2 hrs after test before measuring final resistance.
12	Low Temperature with Load	$\leq 50\text{m}\Omega$	$\pm(1\%+0.05\Omega)$	JIS C 5202 7.1 -55±5°C for 90 minutes, 0.1 rated continuous working voltage as per 3.5 shall be applied for 45 ± ₀ ⁵ minutes. Voltage Sample shall be left at ambient temperature for ≈ 8 hrs after the removal of the voltage for 15 ± ₀ ⁵ before measuring final resistance.
13	High Temperature	$\leq 100\text{m}\Omega$	$\pm(1\%+0.05\Omega)$	JIS C 5202 7.2 125±5°C for 1000 ± ₀ ⁴⁸ hours Sample shall be left at ambient temperature for 1~ 2 hrs after test before measuring final resistance.



14	Thermal Shock (Temperature Cycling)	$\leq 50\text{m}\Omega$	$\pm(0.5\%+0.05\Omega)$ for 1% tolerance resistor $\pm(1\%+0.05\Omega)$ for 2%, 5% tolerance resistor	<p>JIS C 5202 7.4</p> <table border="1"> <thead> <tr> <th>Step</th> <th>Temp. (°C)</th> <th>Time (Minute)</th> </tr> </thead> <tbody> <tr> <td>1</td> <td>-55±5</td> <td>30 mins</td> </tr> <tr> <td>2</td> <td>25±5</td> <td>5 mins max</td> </tr> <tr> <td>3</td> <td>155±5</td> <td>30 mins</td> </tr> <tr> <td>4</td> <td>25±5</td> <td>5 mins max</td> </tr> </tbody> </table> <p>Repeat step 1 to 4 for 5 cycles</p>	Step	Temp. (°C)	Time (Minute)	1	-55±5	30 mins	2	25±5	5 mins max	3	155±5	30 mins	4	25±5	5 mins max
Step	Temp. (°C)	Time (Minute)																	
1	-55±5	30 mins																	
2	25±5	5 mins max																	
3	155±5	30 mins																	
4	25±5	5 mins max																	
15	Resistance to damp Heat (Humidity)	$\leq 100\text{m}\Omega$	$\pm(0.5\%+0.05\Omega)$ for 1% tolerance resistor $\pm(2.0\%+0.05\Omega)$ for 2%, 5% tolerance resistor	<p>JIS C 5202 7.5</p> <p>40±5°C and 90~95%RH for 1000±₀⁴⁸hours Sample shall be left at ambient temperature for 1~ 2 hrs after test before measuring final resistance.</p>															
16	Loadlife	$\leq 100\text{m}\Omega$	$\pm(1.0\%+0.05\Omega)$ for 1% tolerance resistor $\pm(3.0\%+0.1\Omega)$ for 2%, 5% tolerance resistor	<p>JIS C 5202 7.10</p> <p>At 70±5°C Apply DC rated voltage at 90minutes On, 30minutes Off for 1000±₀⁴⁸hours Sample shall be left at ambient temperature for 1~ 2 hrs after test before measuring final resistance.</p>															

6.1 Soldering Profile

6.1.1 Flow Soldering

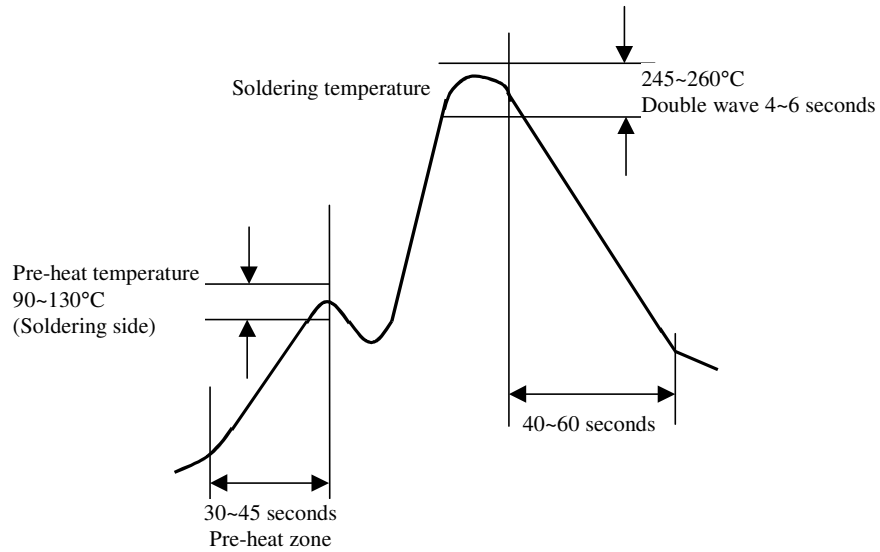

6.1.2 Reflow Soldering

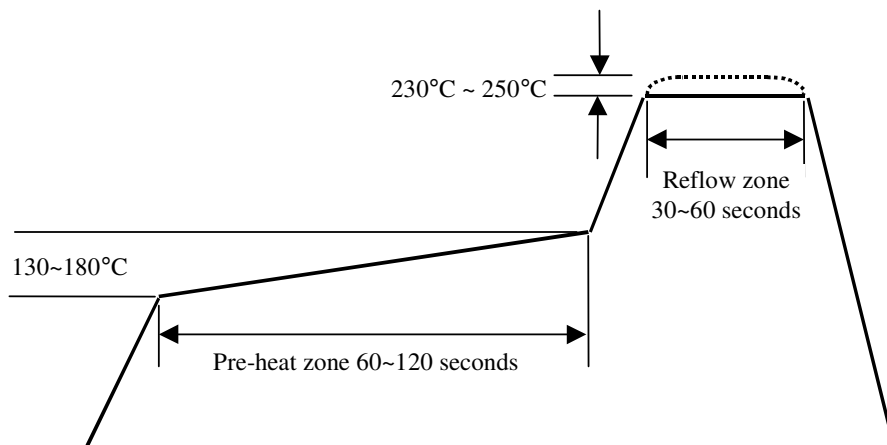

7.0 TAPING

7.1 Structure of Taping

Taping of Rectangularly Punched Carrier System

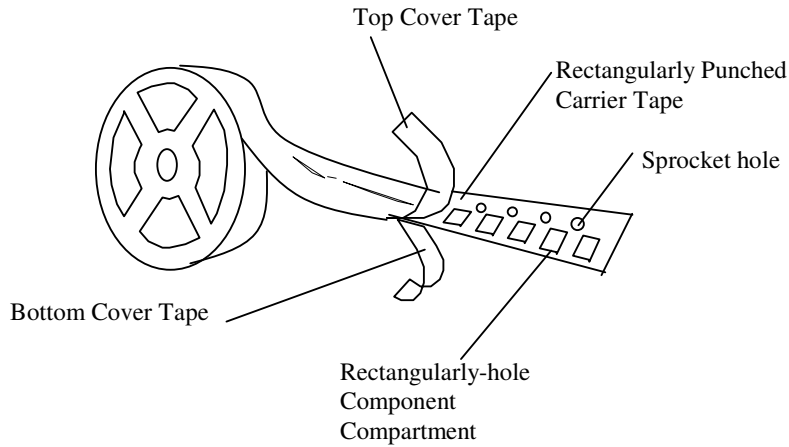

7.2 Materials

- (1) Every taping shall consist of materials as shown in Table 4.
- (2) Every taping shall not adversely affect the mechanical, electrical and solderability performances.
- (3) Materials of taping shall generate no statics.
- (4) The taped products are stored at a temperature -5 to +40°C and a relative humidity 40 to 60% without exposing to direct sunlight and, after such conditioning, the tape shall show no deterioration in performances such as change in adhesion force or peel forces.

Table 4 Materials of Taping

Type	Carrier Tape	Top Cover Tape	Bottom Cover Tape
Taping of Rectangularly Punched Carrier System	Paper	Thermal adhesion polyester	Thermal adhesion paper

ASJ	TITLE: LEAD FREE CHIP RESISTOR NETWORK SPECIFICATION - CONCAVE	REV: D
	DOC NO: SYS-ENG-208	PAGE: 13 of 18

7.3 Leader and Trailer Tape

- 1) Leader Tape The length of leader tape shall be at least 400 mm including 20 or more of rectangular holes (component compartments) in which no component is placed. The 20 or more empty component compartments shall be sealed with the top cover tape (see Fig. 2).
- 2) Trailer Tape The trailer tape at the hub of reel shall be least 40 mm in length including carrier tape with empty component compartments. The empty component compartments shall be sealed with the top cover tape.

The last portion of the carrier tape shall release from the reel hub.

Fig. 2 Explanation of Leader and Trailer Tape

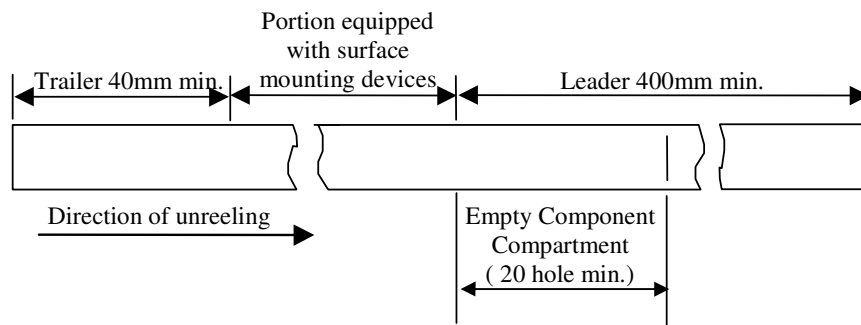

7.4 Position of Taped Component

Position of Taped component The angle made by the center line of taped component and the center line of component compartment shall not exceed 20 degrees (see Fig. 3).

Fig. 3 Angle between Center Line of Component and Center Line of Component compartment

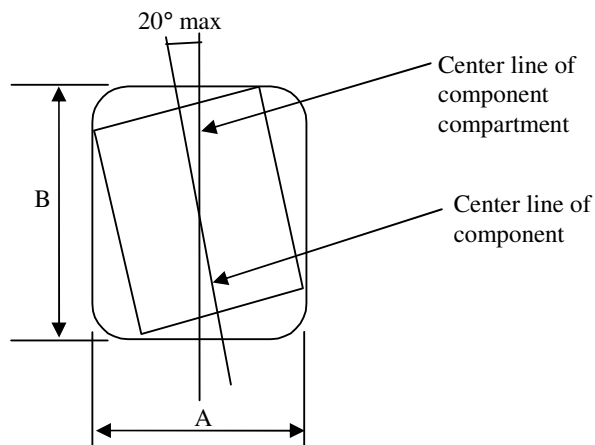

7.5 Tape Dimension

7.5.1 Paper Tape

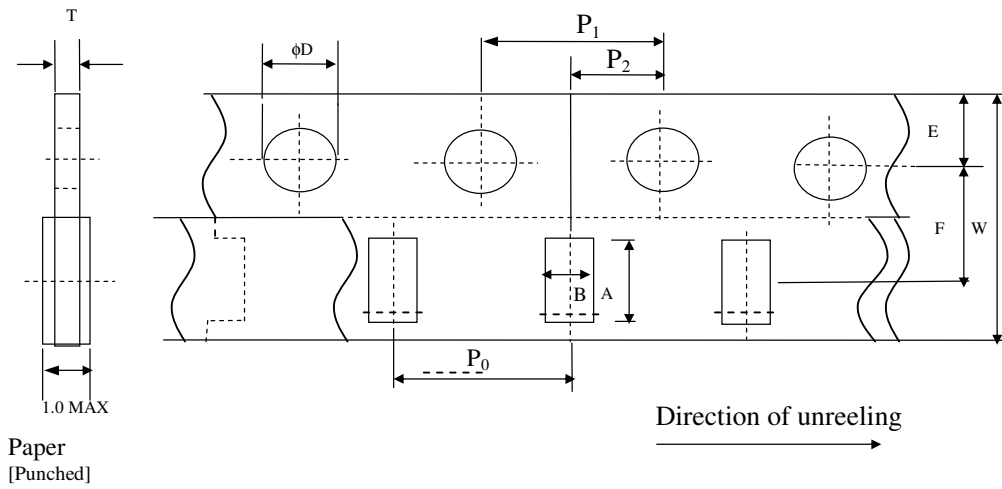

Remark : Pitch tolerance over any 10 pitches of P_0 is ± 0.20 mm

Type	No of resistor	A	B	W	E	F	T	Po,P1	P2	ϕD
TCN10	4	2.20 \pm 0.10	2.00 \pm 0.20	8.00 \pm 0.20	1.75 \pm 0.10	3.50 \pm 0.05	0.45 \pm 0.10	4.00 \pm 0.10	2.00 \pm 0.05	1.50 \pm 0.10
TCN16	4	3.50 \pm 0.10	2.00 \pm 0.20	8.00 \pm 0.20	1.75 \pm 0.10	3.50 \pm 0.05	0.75 \pm 0.10	4.00 \pm 0.10	2.00 \pm 0.05	1.50 \pm 0.10

Unit of Measurement : mm

7.6 Performance of Taping

7.6.1 Strength of carrier tape and top cover tape

When a tensile force of 10N (1.02 kgf) is applied in the direction of unreeling the tape, the carrier tape and top cover tape shall withstand this force.

7.6.2 Peel force of top cover tape

The peel force of top cover tape shall be 0.1N to 0.7N (10 to 70 gf) when the top cover tape is pulled at a speed of 200mm/min with the angle between the tape during peel and the direction of unreeling maintained at 165 to 180 degree as illustrated in Fig 4.

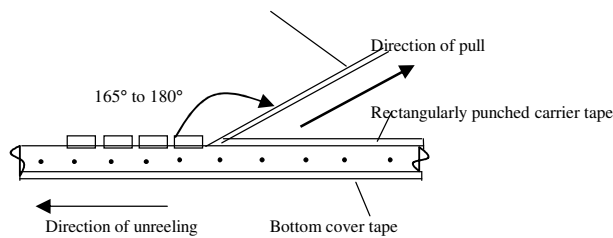

Fig. 4 Peeling Test

7.6.3 Minimum Bending Radius

When the tape is bent with the minimum bending radius specified in Fig 5 and Table 5, components shall maintain their position and shall be free from abnormalities such as damage.

Table 5

Type	Minimum Bending Radius
TCN10	30.0 mm
TCN16	40.0 mm

Fig. 5 Explanation of Minimum Bending Radius

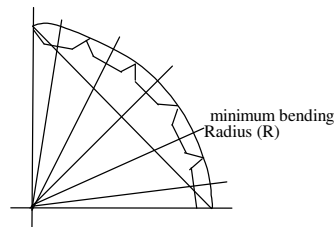

ASJ	TITLE: LEAD FREE CHIP RESISTOR NETWORK SPECIFICATION - CONCAVE	REV: D
	DOC NO: SYS-ENG-208	PAGE: 16 of 18

7.7 Packaging

7.7.1 Standard Packaging Pan Size

Packaging	No. of Resistor	4
Tape	TCN10	5K, 10K &
	TCN16	20K

7.7.2 Identification

A label indicating product type, resistance value and tolerance shall be pasted on the surface of each reel.

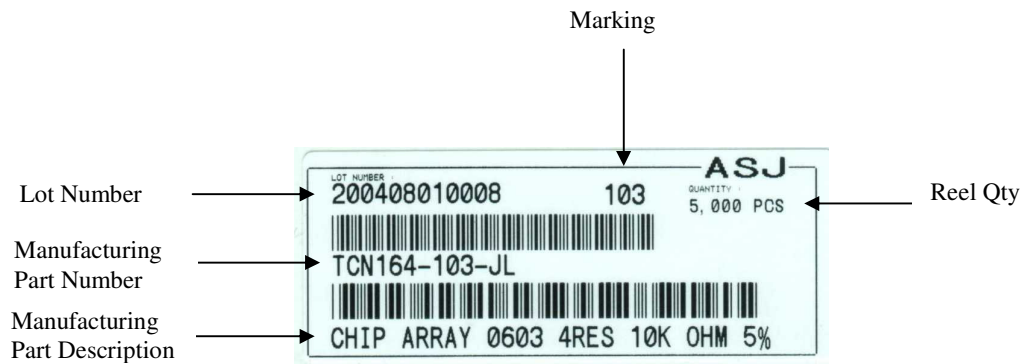

How to read lot Number :

XXXX	XX	XX	XXXX
Year	Mth	Day	Serialize Number

Lot No: 00016492	ASJ
Date Code : 20050402	Qty : 5 KU
YCN164-4750-FL	
CHIP ARRAY 0603 4RES 475R OHM 1%	

Lot Number : 8 digits running numbers

Date Code : YYYYMMDD

YYYY - Year
MM - Month
DD - Date

7.7.3 Reel Dimension

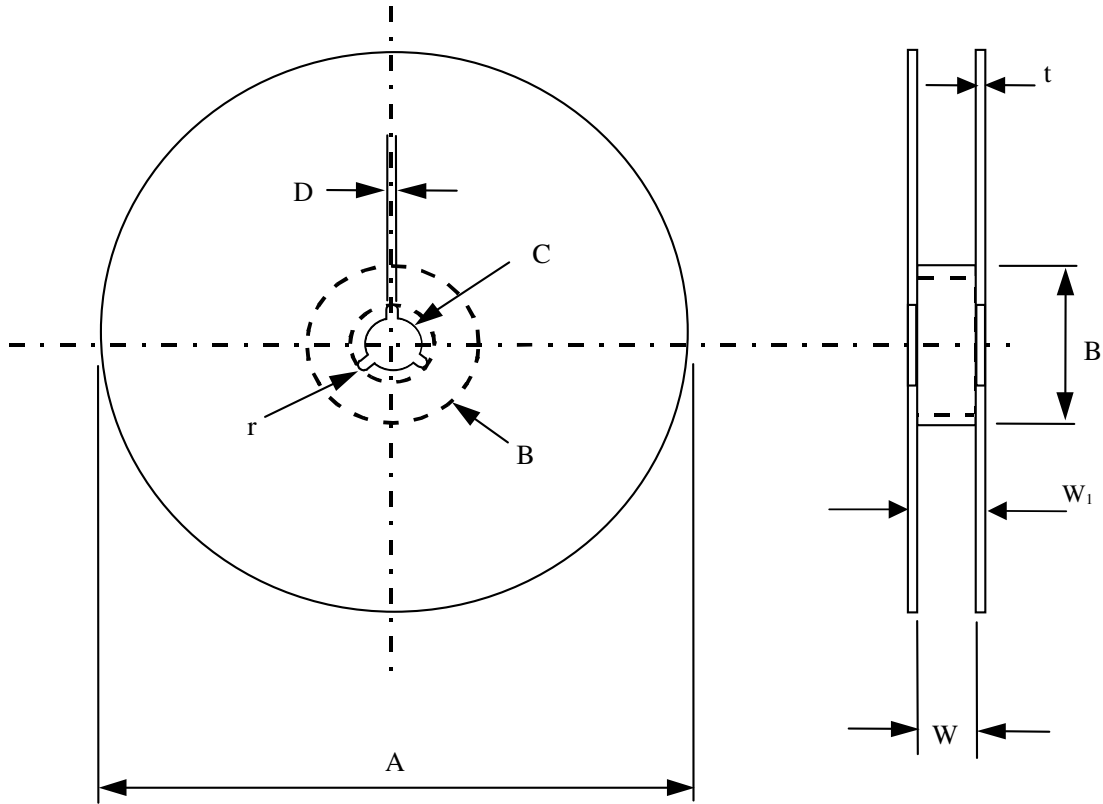

TYPE	NO OF RESISTOR	A	B	C	D	W	W ₁	t	r
TCN 10	4	φ178±2.0	φ60 ± ¹ ₀	13± 0.2	2.0± 0.5	11±1.0	14.4 max	1.0± 0.1	1.0
TCN 16	4	φ178±2.0	φ60 ± ¹ ₀	13± 0.2	2.0± 0.5	11±1.0	14.4 max	1.0± 0.1	1.0

Unit of Measurement : mm

8.0 SOLDER LAND PATTERN

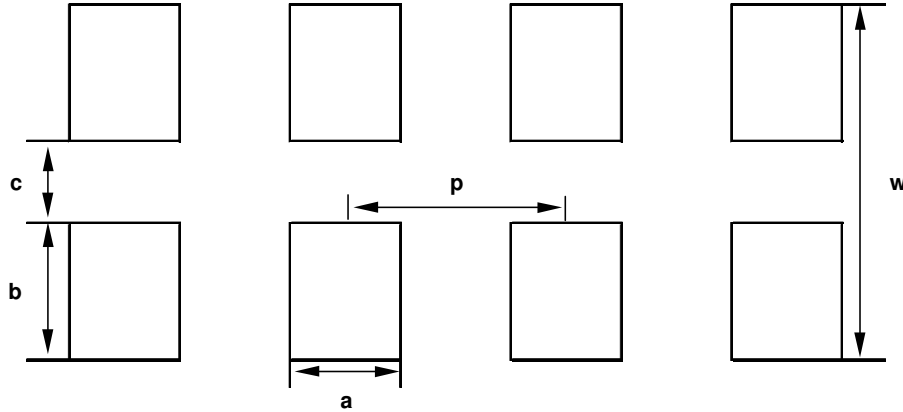

Part	c	w	p	a	b
TCN104	0.4	2.0	0.5	0.25	0.8
TCN164	0.7	3.0	0.8	0.44	1.15

Unit of Measurement : mm

9.0 APPLICABLE STANDARDS

JIS C 5202	Test Methods of Fixed Resistors for Electronic Equipment.
JIS C 0806	Packaging of Electronic Components on continuous tapes (surface mount devices).
MIL-STD-202	Test Methods for Electronic and Electrical Parts.
IPC/JEDEC J STD 020B	Moisture / Reflow sensitivity classification for non hermetic solid state surface mount devices.
2002/95/EC	RoHS Directive