



**ASJ PTE LTD**

<b>LEAD FREE CHIP RESISTOR SPECIFICATION (HIGH VOLTAGE)</b>	
Reference No.	: SYS-ENG-210
Revision No.	: D

<b>ASJ</b>	LEAD FREE CHIP RESISTOR SPECIFICATION (HIGH VOLTAGE)	<b>REV: D</b>
	DOC NO: SYS-ENG-210	PAGE: 2 of 24

1.0	SCOPE.....	3
2.0	PART NUMBERING SYSTEM.....	3
3.0	RATING.....	3
3.1	Rating Power.....	3
3.2	Power Derating Characteristic .....	4
3.3	Standard Atmospheric Condition .....	4
3.4	Operating Temperature Range.....	4
3.5	Storage Temperature Range.....	4
3.6	Flammability Rating .....	4
3.7	Moisture Sensitivity Rating Level .....	4
3.8	Product Assurance .....	4
3.9	RoHS Compliance .....	4
3.10	Resistance Range, Resistance Tolerance & Temperature Coefficient of Resistance .....	5
3.11	Rated Voltage.....	5
4.0	MARKING ON PRODUCT.....	6
4.1	Numeric Numbering .....	6-7
5.0	DIMENSIONS, CONSTRUCTION AND MATERIALS.....	7
5.1	Dimensions.....	7
5.2	Zero ohm Construction.....	8
5.3	Resistor Construction .....	8
5.4	Materials.....	9
6.0	ELECTRICAL CHARACTERISTICS AND TEST CONDITIONS.....	10-14
6.1	Soldering Profile .....	15
6.2.1	Flow Soldering .....	15
6.2.2	Reflow Soldering .....	15
7.0	TAPING.....	16
7.1	Structure of Taping.....	16
7.2	Materials.....	16
7.3	Leader and Trailer Tape.....	17
7.4	Position of Taped Component.....	17
7.5	Dimension of Punched Paper Tape Carrier System .....	18
7.6	Performance of Taping.....	19
7.6.1	Strength of Carrier tape and top cover tape .....	19
7.6.2	Peel force of top cover tape .....	19
7.6.3	Minimum Bending Radius .....	19
7.6.4	Number of missing components and mistake in taping .....	20
7.7	Packaging.....	20
7.7.1	Taping.....	20
7.7.2	Identification .....	21
7.7.3	Packaging Reel Box .....	21
7.7.4	Reel Dimensions.....	22
7.7.5	Bulk Cassette Packaging.....	23
8.0	Surface Mount Land Patterns .....	24
9.0	Applicable Standards.....	24

<b>ASJ</b>	LEAD FREE CHIP RESISTOR SPECIFICATION (HIGH VOLTAGE)	REV: D
	DOC NO: SYS-ENG-210	PAGE: 3 of 24

## 1.0 SCOPE

This specification specifies fixed thick film chip resistor (referred to as resistor hereinafter) for use in electronic equipment. In case there are discrepancies in specifications between this specification and the Customer's specifications, the latter shall precede.

## 2.0 PART NUMBERING SYSTEM

Part Numbering is made in accordance with the following system:

<u>CR</u>	<u>XX</u>	-	<u>XXXX</u>	-	<u>X</u>	<u>X</u>
Resistance			Resistance Value		Tolerance	Packaging
CR24 - 0805					D - 0.5%	L - 5K reel
CR34 - 1206					F - 1%	K - 10K reel
CR42 - 1210					G - 2%	E - 4K reel
CR52 - 2010					J - 5%	
CR66 - 2512					K - 10%	
					M - 20%	
					Z - Zero ohm	

## 3.0 RATING

### 3.1 Rated Power

#### 3.1.1 Zero Ohm Jumper Rated Power

	Rated Current	Maximum Working Current	Maximum Overload Current	Dielectric Withstanding Current	Resistance Tolerance
CR24	2A	2A	5A	500V	< 50m Ω
CR34	2A	2A	5A	500V	< 50m Ω
CR42	2A	2A	5A	500V	< 50m Ω
CR52	2A	2A	5A	500V	< 50m Ω
CR66	3A	3A	15A	500V	< 50m Ω

#### 3.1.2 Resistor Rated Power

	Rated Power	Maximum Working Voltage	Maximum Overload Voltage	Maximum Intermittent Overload Voltage	Dielectric Withstanding Voltage
CR24	1/4W	150V	300V	300V	500V
CR34	1/2W	200V	400V	400V	500V
CR42	3/4W	200V	400V	400V	500V
CR52	1W	200V	400V	400V	500V
CR66	2W	200V	400V	400V	500V

<b>ASJ</b>	LEAD FREE CHIP RESISTOR SPECIFICATION (HIGH VOLTAGE)	REV: D
	DOC NO: SYS-ENG-210	PAGE: 4 of 24

### 3.2 Power Derating Characteristics

Rated Power shall be the load power corresponding to nominal wattage suitable for continuous use at 70°C ambient temperature. In case the ambient temperature exceeds 70°C, reduce the load power in accordance with Derating curve in Fig. 1.

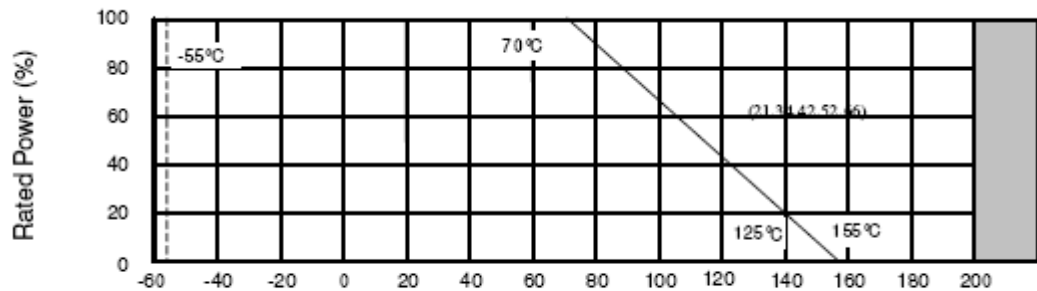

Fig.1 Power Derating Characteristics

### 3.3 Standard Atmospheric Condition

Unless otherwise specified, the standard range of atmospheric conditions for making measurements and tests is as follows :

Ambient Temperature = +5°C to +35°C  
 Relative Humidity = < 85% RH  
 Air Pressure = 86 to 106kPa

If there may be any doubt about the results, measurement shall be made within the following limits :

Ambient Temperature = 20± 2°C  
 Relative Humidity = 60 to 70%  
 RH Air Pressure = 86 to 106kPa

3.4 Operating Temperature Range -55°C to +155°C

3.5 Storage Temperature Range -5°C to +40°C

3.6 Flammability Rating Tested in accordance to UL-94, V-0

3.7 Moisture Sensitivity Level Rating : Level 1

3.8 Product Assurance

ASJ resistor shall warranty 12 months from the date of shipment.

3.9 ASJ resistors are RoHS compliance in accordance to RoHS Directive 2002/95/EC.

<b>ASJ</b>	LEAD FREE CHIP RESISTOR SPECIFICATION (HIGH VOLTAGE)	<b>REV: D</b>
	DOC NO: SYS-ENG-210	PAGE: 5 of 24

### 3.10 Resistance, Resistance Tolerance and Temperature Coefficient of Resistance.

Table 1	Resistance Range			
	D (+/- 0.5%) E - 96	F (+/- 1%) E - 96 E - 24	G (+/- 2%) E - 24	J (+/- 5%) E - 24
CR24 (0805)	0.1Ω to 30MΩ	0.1Ω to 30MΩ	0.1Ω to 30MΩ	0.1Ω to 30MΩ
CR34 (1206)	0.1Ω to 30MΩ	0.1Ω to 30MΩ	0.1Ω to 30MΩ	0.1Ω to 30MΩ
CR42 (1210)	0.1Ω to 30MΩ	0.1Ω to 30MΩ	0.1Ω to 30MΩ	0.1Ω to 30MΩ
CR52 (2010)	0.1Ω to 30MΩ	0.1Ω to 30MΩ	0.1Ω to 30MΩ	0.1Ω to 30MΩ
CR66 (2512)	0.1Ω to 30MΩ	0.1Ω to 30MΩ	0.1Ω to 30MΩ	0.1Ω to 30MΩ
Temperature Coefficient Resistance (TCR)	0201 only	1Ω to 10Ω 10Ω to 1MΩ	-100/+600ppm/°C ±250ppm/°C	
	0.5% & 1% (For all product type)	0.1 ≤ R < 10Ω 10Ω ≤ R < 1MΩ 1MΩ ≤ R ≤ 30MΩ	±200ppm/°C ±100ppm/°C ±200ppm/°C	
	2% & 5% (For all product type)	0.1 ≤ R < 10Ω 10Ω ≤ R < 1MΩ 1MΩ ≤ R ≤ 30MΩ	±200ppm/°C ±100ppm/°C ±200ppm/°C	
Zero Ohm Jumper < 0.05Ω				

### 3.11 Rated Voltage

The rated voltage is calculated from the rated power and nominal resistance by the following formula:

$$E = \sqrt{P \cdot R}$$

Where E : Rated Voltage (V)

P : Rated Power (W)

R : Nominal Resistance (Ω)

In case the value calculated by the formula exceeds the maximum working voltage given in Section 3.1.2, the maximum working voltage in Section 3.1.2 shall be regarded as the rated voltage.

<b>ASJ</b>	LEAD FREE CHIP RESISTOR SPECIFICATION (HIGH VOLTAGE)	REV: D
	DOC NO: SYS-ENG-210	PAGE: 6 of 24

#### 4.0 MARKING ON PRODUCT

The nominal resistance shall be marked on the surface of each resistor.

Part Number	Color	Marking on Product
CR24 (0805)	Light Brown	1) Tolerance : +/-1.0% (F) ° Four Numerals Marking (E96 Series)
CR34 (1206)	Light Brown	
CR42 (1210)	Light Brown	2) Tolerance : ± 2% (G), ±5.0% (J), ±10% (K)  Three Numerals Marking
CR52 (2010)	Light Brown	
CR66 (2512)	Light Brown	3) Zero ohm jumper resistor The marking used shall be 0

#### 4.1 Numeric Numbering

##### 4.1.1 5% Tolerance : **Three Numerals Marking**

First 2 digits are significant figures, third digit is number of zeros. Letter R is decimal point.

Example

<i>Nominal Resistance</i>	<i>Marking</i>	<i>Remarks</i>
1 Ω	1R0	$1 \times 10^0 = 1$
10 Ω	100	$10 \times 10^0 = 10$
100 Ω	101	$10 \times 10^1 = 100$
4.7K Ω	472	$47 \times 10^2 = 4700$
47K Ω	473	$47 \times 10^3 = 47000$
470K Ω	474	$47 \times 10^4 = 470000$
4.7M Ω	475	$47 \times 10^5 = 4700000$

<b>ASJ</b>	LEAD FREE CHIP RESISTOR SPECIFICATION (HIGH VOLTAGE)	REV: D
	DOC NO: SYS-ENG-210	PAGE: 7 of 24

4.1.2 1% Tolerance : **Four Numerals Marking**

First 3 digits are significant figures, fourth digit is number of zeros.

Example :

<i>Nominal Resistance</i>	<i>Marking</i>	<i>Remarks</i>
1 Ω	1R00	$1 \times 10^0 = 1$
10 Ω	10R0	$10 \times 10^0 = 10$
100 Ω	1000	$100 \times 10^0 = 100$
4.7K Ω	4701	$470 \times 10^1 = 4700$
47K Ω	4702	$470 \times 10^2 = 47000$
470K Ω	4703	$470 \times 10^3 = 470000$
1M Ω	1004	$100 \times 10^4 = 1000000$

## 5.0 DIMENSIONS, CONSTRUCTIONS AND MATERIALS

### 5.1 Dimensions

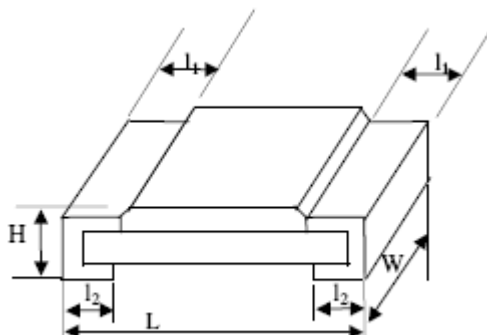

Unit : Inches (Millimeters)

CODE	L	W	H	l <sub>1</sub>	l <sub>2</sub>
CR24 (0805)	0.079±0.006 (2.00±0.15)	0.049±0.004 (1.25±0.10)	0.020±0.004 (0.50±0.10)	0.016±0.008 (0.40±0.20)	0.016±0.008 (0.40±0.20)
CR34 (1206)	0.122±0.004 (3.10±0.10)	0.063±0.006 (1.60±0.15)	0.022±0.002 (0.55±0.05)	0.020±0.010 (0.50±0.25)	0.020±0.010 (0.50±0.25)
CR42 (1210)	0.122±0.004 (3.10±0.10)	0.098±0.006 (2.50±0.15)	0.022±0.002 (0.55±0.05)	0.020±0.010 (0.50±0.25)	0.016±0.008 (0.40±0.20)
CR52 (2010)	0.200±0.006 (5.00±0.15)	0.098±0.006 (2.50±0.15)	0.022±0.002 (0.55±0.05)	0.024±0.010 (0.60±0.25)	0.016±0.008 (0.40±0.20)
CR66 (2512)	0.250±0.006 (6.30±0.15)	0.126±0.006 (3.20±0.15)	0.022±0.002 (0.55±0.05)	0.024±0.010 (0.60±0.25)	0.016±0.008 (0.40±0.20)

<b>ASJ</b>	LEAD FREE CHIP RESISTOR SPECIFICATION (HIGH VOLTAGE)	REV: D
	DOC NO: SYS-ENG-210	PAGE: 8 of 24

5.2 Zero Ohm Construction

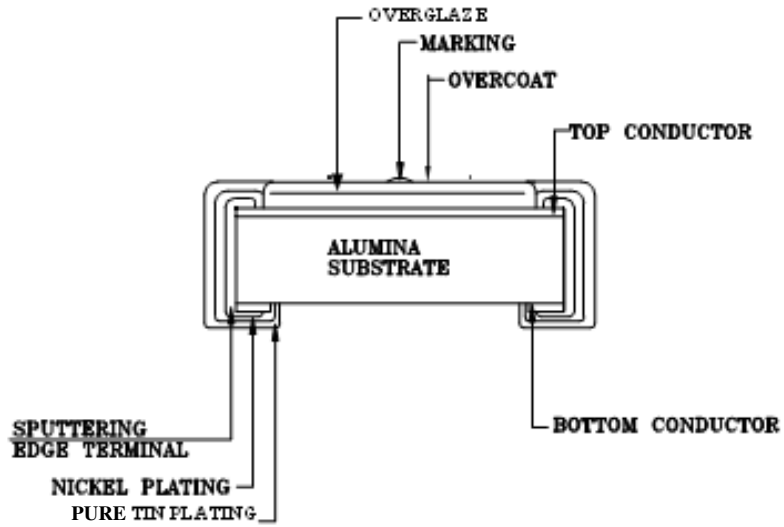

5.3 Resistor Construction

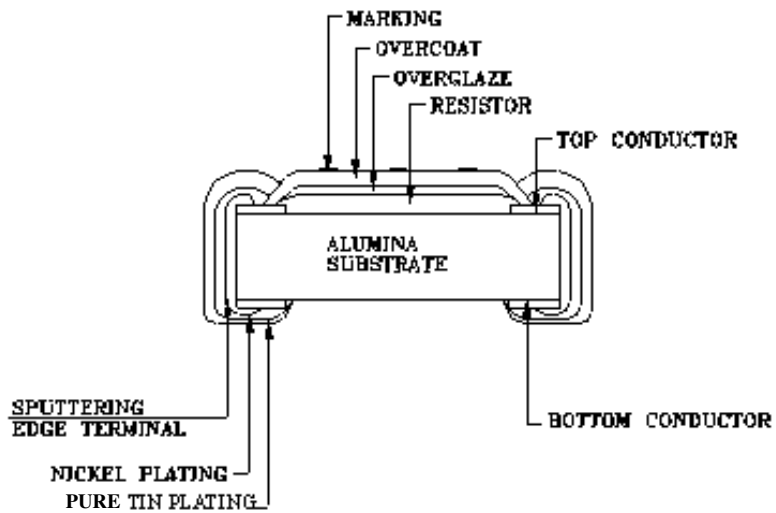

<b>ASJ</b>	LEAD FREE CHIP RESISTOR SPECIFICATION (HIGH VOLTAGE)	<b>REV: D</b>
	DOC NO: SYS-ENG-210	PAGE: 9 of 24

#### 5.4 Materials

<i>Construction</i>		<i>Material Used</i>	<i>Thickness</i>
Substrate	Ceramic Substrate	Alumina substrate, 96% purity	-
Resistive body ( Not for Zero ohm)	Resistor	Ruthenium oxide	-
Protective Film	Overglaze	Borosilicate-glass	-
	Overcoat	Epoxy Polymer	-
Internal Electrode	Top/ Bottom Conductor	Silver palladium	30± 2µm (Wet)
Secondary Electrode	Nickel Plating	Nickel	2.5 ~ 12 µm
Tertiary Electrode	Pure Tin Plating	Tin, Sn	3.0 ~ 15 µm
Edge Terminal	Sputtering 0805,1206,1210,2010, 2512	Nickel Chromium	0.08 ~ 0.2 µm

<b>ASJ</b>	LEAD FREE CHIP RESISTOR SPECIFICATION (HIGH VOLTAGE)	REV: D
	DOC NO: SYS-ENG-210	PAGE: 10 of 24

## 6.0 ELECTRICAL CHARACTERISTICS AND TEST CONDITIONS

CHARACTERISTICS		SPECIFICATIONS		TESTING CONDITIONS														
		Zero Ohm	Resistance															
1	Resistance Value	≤ 50 mΩ	Resistance accuracy being fully relies with respect to tolerance of resistor.	<p><b>JIS C 5202 5.1</b> Application time to be within 5 secs .</p> <p>Applied Voltage for resistance measurement :</p> <table border="1" style="width: 100%; border-collapse: collapse;"> <tr> <td style="width: 50%;"><math>&lt;10\Omega</math></td> <td style="width: 50%;">0.1V</td> </tr> <tr> <td>10~99Ω</td> <td>0.3V</td> </tr> <tr> <td>100~999</td> <td>1.0V</td> </tr> <tr> <td>1K~ 9.9K</td> <td>3.0 V</td> </tr> <tr> <td>10K~ 99.9K</td> <td>10.0 V</td> </tr> <tr> <td>100K~999K</td> <td>30.0 V</td> </tr> <tr> <td>1M &amp; Over</td> <td>50.0 V</td> </tr> </table>	$<10\Omega$	0.1V	10~99Ω	0.3V	100~999	1.0V	1K~ 9.9K	3.0 V	10K~ 99.9K	10.0 V	100K~999K	30.0 V	1M & Over	50.0 V
$<10\Omega$	0.1V																	
10~99Ω	0.3V																	
100~999	1.0V																	
1K~ 9.9K	3.0 V																	
10K~ 99.9K	10.0 V																	
100K~999K	30.0 V																	
1M & Over	50.0 V																	
2	Resistance Temperature Coefficient	NA	Refer Section 3.5 Table 1	<p><b>JIS C 5202 5.2</b> Measure R at <math>t_0=25^{\circ}\text{C}</math> and after 45 minutes measure R at <math>t=125^{\circ}\text{C}</math>.</p> <p>Calculation :</p> $\text{TCR}(\text{ppm}/^{\circ}\text{C}) = \frac{R - R_0}{R_0} * \frac{1}{t - t_0} * 10^6$														
3	Voltage Coefficient (Applicable for $>1\text{K}\Omega$ only)	NA	Voltage coefficient ≤ 100ppm/V	<p><b>JIS C 5202 5.3 Method II</b> Apply DC Voltage, <math>E_2=1/10</math> rated voltage and <math>E_1=100\%</math> rated voltage to Rx. Measure voltage <math>V_1</math> &amp; <math>V_2</math> across Rs. Voltage applied shall be 3secs or less during 5secs of <math>E_1</math> and not more than 10secs during <math>E_2</math></p> <p>Calculation :</p> $V_c(\%/V) = \frac{(V_2 * 10) - V_1}{V_1} * \frac{1}{E_1 - E_2} * 100$														
4	Short Time Overload	≤ 50 mΩ	±0.5% for 1% tolerance resistor ±1.0% for 5% tolerance resistor	<p><b>JIS C 5202 5.5</b> Apply at 2.5 times rated voltage for 5 seconds. Applied voltage shall not exceed maximum overload voltage or current.</p>														

<b>ASJ</b>	LEAD FREE CHIP RESISTOR SPECIFICATION (HIGH VOLTAGE)		REV: D
	DOC NO: SYS-ENG-210		PAGE: 11 of 24

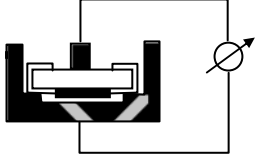
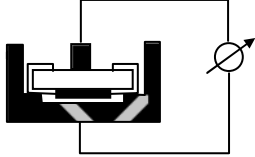
5	Insulation Resistance	$> 10G \Omega$		<p><b>JIS C 5202 5.6</b> Apply 500V <math>\pm</math> 15VDC for 1 minute for chip <math>\geq</math> 0805. Apply 300V <math>\pm</math> 15VDC for 1 minute for chip 0402 &amp; 0603</p> 														
6	Dielectric Withstanding	No failure of resistor such as short-circuit, burning, breakdown.		<p><b>JIS C 5202 5.7</b> Apply 500VAC for 1 minute <math>\pm</math> 10secs. for chip <math>\geq</math> 0805. Apply 300VAC for 1 minute <math>\pm</math> 10secs. for chip 0402 &amp; 0603</p>  <p>The variation in relation to the initial resistance shall be within <math>\pm 1\%</math>.</p>														
	Voltage	$\leq 50 m\Omega$	$\pm(1\%+0.05\Omega)$ for 1% & 5% tolerance resistor															
7	Intermittent Overload	$\leq 100m\Omega$	$\pm(5\%+0.1\Omega)$ for 1% & 5% tolerance resistor	<p><b>JIS C 5202 5.8</b> Apply 4 times rated voltage for 1 secs ON and 25 secs OFF. Total 10 000 <sup>+400</sup> cycles Applied voltage/current shall not exceed maximum intermittent overload voltage/ current.</p>														
8	Noise	NA	<table border="0"> <tr><td>1~9</td><td>-10dB(0.32<math>\mu</math>v/v)</td></tr> <tr><td>10~99</td><td>- 5 dB(0.52<math>\mu</math>v/v)</td></tr> <tr><td>100~999</td><td>0 dB(1.0<math>\mu</math>v/v)</td></tr> <tr><td>1K~9.9K</td><td>10 dB(3.2<math>\mu</math>v/v)</td></tr> <tr><td>10K~99.9K</td><td>18 dB(5.6<math>\mu</math>v/v)</td></tr> <tr><td>100K~999.9K</td><td>20 dB(10<math>\mu</math>v/v)</td></tr> <tr><td>&gt;1M</td><td>30 dB(32<math>\mu</math>v/v)</td></tr> </table>	1~9	-10dB(0.32 $\mu$ v/v)	10~99	- 5 dB(0.52 $\mu$ v/v)	100~999	0 dB(1.0 $\mu$ v/v)	1K~9.9K	10 dB(3.2 $\mu$ v/v)	10K~99.9K	18 dB(5.6 $\mu$ v/v)	100K~999.9K	20 dB(10 $\mu$ v/v)	>1M	30 dB(32 $\mu$ v/v)	<p><b>JIS C 5202 5.9</b> <math>V_n(\text{dB}) = T-f(T-S)-D</math></p>
1~9	-10dB(0.32 $\mu$ v/v)																	
10~99	- 5 dB(0.52 $\mu$ v/v)																	
100~999	0 dB(1.0 $\mu$ v/v)																	
1K~9.9K	10 dB(3.2 $\mu$ v/v)																	
10K~99.9K	18 dB(5.6 $\mu$ v/v)																	
100K~999.9K	20 dB(10 $\mu$ v/v)																	
>1M	30 dB(32 $\mu$ v/v)																	

<b>ASJ</b>	LEAD FREE CHIP RESISTOR SPECIFICATION (HIGH VOLTAGE)	REV: D
	DOC NO: SYS-ENG-210	PAGE: 12 of 24

9	Terminal Strength  A) Bend Test (Applicable for chip size smaller than CR40) B) Pull Test (Applicable for chip size bigger than CR24) C) Push Test  D) Robushness test	$\leq 50\text{m}\Omega$	Tolerance resistor. With no evidence of mechanical damage after releasing the pressure. $\pm(0.5\%+0.05\Omega)$ for 1% & 5%  $\pm(1.0\%+0.05\Omega)$ for 1% & 5%  $\pm(1.0\%+0.05\Omega)$ for 1% & 5%  After reading/initial reading >50-%	<b>JIS C 5202 6.1</b>  <b>JIS C 5202 6.1.4(1) Method 2</b> Bend Test : Apply force till 3mm bend and hold for 5±1 secs. Measure resistance while applying pressure. Pull Test : Apply 0.5kgF for 30±5 secs  <b>JIS C 5202 6.1.4(3) Method B</b> Push Test : Apply 1.2kgF for 60±5secs  Component mounted on board precondition using steam aging for 4 hour. Initial reading = Force required to break away components mounted on board. After Reading = Force required to break away components mounted on board after preconditioned.
10	Resistance to soldering heat	$\leq 50\text{m}\Omega$	$\pm(0.5\%+0.05\Omega)$ for 1% & 5% tolerance resistor	<b>JIS C 5202 6.10</b> A) Solder bath method Resistor dipped entirely in solder bath of 260±5°C for 10 <sub>0</sub> <sup>+1</sup> sec. B) Flow soldering Preheat : 100°C to 105°C for 30±5 sec. Resistor dipped entirely in solder bath of 265±3°C for 5 <sub>0</sub> <sup>+1</sup> C) Reflow soldering method Peak : 250 <sub>0</sub> <sup>+5</sup> °C 230±5°C for 30 - 40secs. D) Soldering Iron method Bit temp.: 350±10°C Application time of soldering iron is 3 <sub>0</sub> <sup>+1</sup> sec. After which the sample shall be left at ambient temperature for 1~ 2 hrs before measurement.

<b>ASJ</b>	LEAD FREE CHIP RESISTOR SPECIFICATION (HIGH VOLTAGE)		REV: D
	DOC NO: SYS-ENG-210		PAGE: 13 of 24

11	Solderability	$\geq 95\%$ Coverage		Precondition by baking 4 hours at 155°C. <b>IEC 60068-2-58</b> Solder bath method : Solder : H60 Flux : 25% Colophony, 75% 2-Propanol by weight. 215±3°C for 2 <sup>+1</sup> <sub>-0</sub> sec
12	Resistance to Solvent	$\leq 50\text{m}\Omega$	$\pm(1\%+0.05\Omega)$ for 1% & 5% tolerance resistor Marking shall be legible without mechanical damage in appearance.	<b>JIS C 5202 6.9</b> Immerse in 20°C~25°C Isoproyl Alcohol solvent for 60±10secs.
13	Low Temperature	$\leq 50\text{m}\Omega$	$\pm(0.5\%+0.05\Omega)$ for 1% tolerance resistor $\pm(1\%+0.05\Omega)$ for 5% tolerance resistor	<b>JIS C 5202 7.1</b> -55±3°C for 1000 ± <sub>0</sub> <sup>48</sup> hours Sample shall be left at ambient temperature for 1~ 2 hrs after test before measuring final resistance.
14	Low Temperature with Load	$\leq 50\text{m}\Omega$	$\pm(0.5\%+0.05\Omega)$ for 1% tolerance resistor $\pm(1\%+0.05\Omega)$ for 5% tolerance resistor	<b>JIS C 5202 7.1</b> -55±3°C for 90 minutes, 0.1 rated continuous working voltage as per 3.5 shall be applied for 45 ± <sub>0</sub> <sup>5</sup> minutes. Voltage Sample shall be left at ambient temperature for ~ 8 hrs after the removal of the voltage for 15 ± <sub>0</sub> <sup>5</sup> before measuring final resistance.
15	High Temperature	$\leq 100\text{m}\Omega$	$\pm(1\%+0.05\Omega)$ for 1% tolerance resistor $\pm(2\%+0.10\Omega)$ for 5% tolerance resistor	<b>JIS C 5202 7.2</b> 155±5°C for 1000 ± <sub>0</sub> <sup>48</sup> hours Sample shall be left at ambient temperature for 1~ 2 hrs after test before measuring final resistance.

<b>ASJ</b>	LEAD FREE CHIP RESISTOR SPECIFICATION (HIGH VOLTAGE)	<b>REV: D</b>
	DOC NO: SYS-ENG-210	PAGE: 14 of 24

16	Temperature Cycling	$\leq 50\text{m}\Omega$	$\pm(0.5\%+0.05\Omega)$ for 1% tolerance resistor $\pm(1\%+0.05\Omega)$ for 5% tolerance resistor	<b><i>JIS C5202 7.4</i></b>		
				Step	Temp. (°C)	Time (minute)
				1	$-55 \pm 5$	30 mins
				2	$25 \pm 5$	5 mins max
				3	$155 \pm 5$	30 mins
				4	$25 \pm 5$	5 mins max
				Repeat step 1 to 4 for 5 cycles		
17	Resistance to damp Heat ( Humidity )	$\leq 100\text{m}\Omega$	$\pm(1\%+0.1\Omega)$ for 1% & 5% tolerance resistor	<b><i>JIS C 5202 7.5</i></b> 40±2°C and 90~95%RH for 1000± <sub>0</sub> <sup>48</sup> hours Sample shall be left at ambient temperature for 1~ 2 hrs after test before measuring final resistance.		
18	Loadlife	$\leq 100\text{m}\Omega$	$\pm(1.0\%+0.05\Omega)$ for 1% tolerance resistor $\pm(2.0\%+0.1\Omega)$ for 5% tolerance resistor	<b><i>JIS C5202 7.10</i></b> At 70±3°C Apply DC rated voltage at 90minutes On, 30minutes Off for 1000± <sub>0</sub> <sup>48</sup> hours Sample shall be left at ambient temperature for 1~ 2 hrs after test before measuring final resistance.		
19	Salt Spray	$\leq 50\text{m}\Omega$	$\pm(3\%+0.1\Omega)$ for 1% & 5% tolerance resistor	<b><i>JIS C5202 7.7</i></b> Spray 5±1 Wt% salt water for 96±4 hours at 35±2°C		

<b>ASJ</b>	LEAD FREE CHIP RESISTOR SPECIFICATION (HIGH VOLTAGE)	<b>REV: D</b>
	DOC NO: SYS-ENG-210	PAGE: 15 of 24

## 6.1 Soldering Profile

### 6.2.1 Flow Soldering

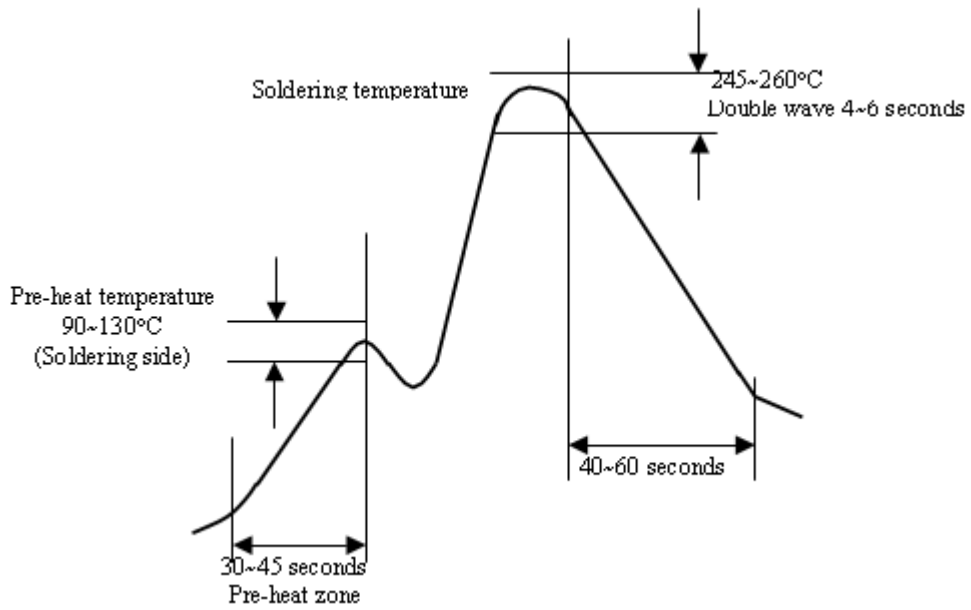

### 6.2.2 Reflow Soldering

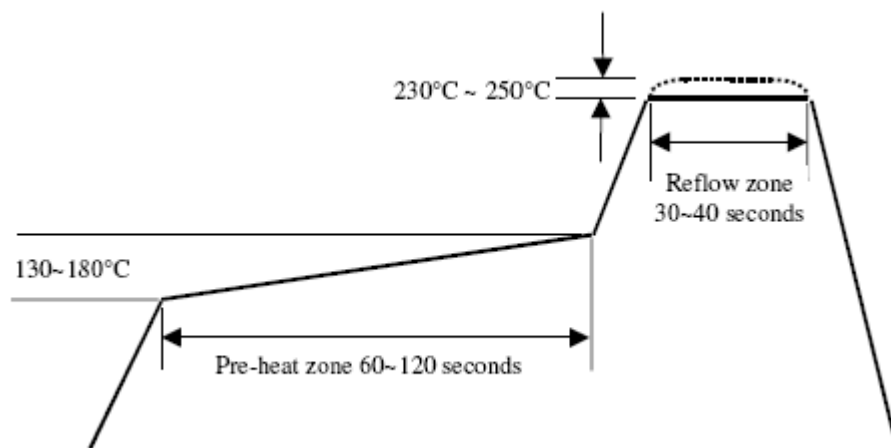

<b>ASJ</b>	LEAD FREE CHIP RESISTOR SPECIFICATION (HIGH VOLTAGE)	REV: D
	DOC NO: SYS-ENG-210	PAGE: 16 of 24

## 7.0 TAPING

### 7.1 Structure of Taping

#### Taping of Rectangularly Punched Carrier System

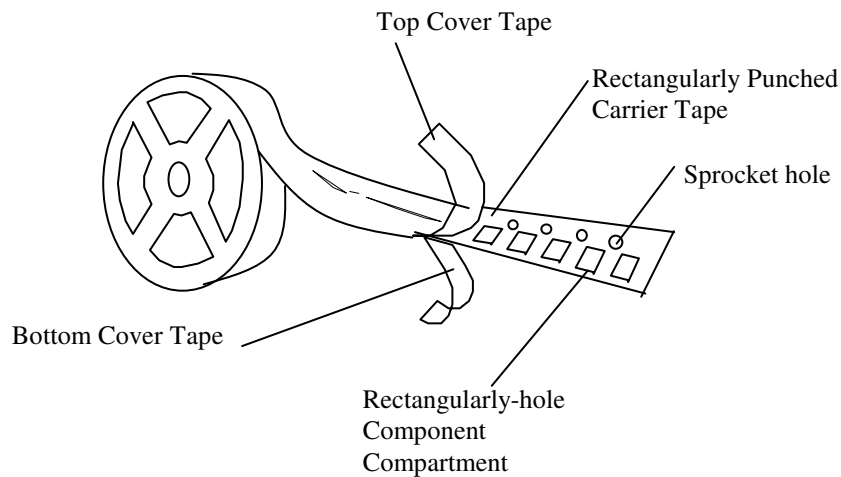

### 7.2 Materials

- (1) Every taping shall consist of materials as shown in Table - 4
- (2) Every taping shall not adversely affect the mechanical, electrical and solderability performances.
- (3) Materials of taping shall generate no statics.
- (4) The taped products are stored at a temperature -5 to +40°C and a relative humidity 40 to 50% without exposing to direct sunlight and, after such conditioning, the tape shall show no deterioration in performances such as change in adhesion force or peel forces.

Table 4 Materials of Taping

	Carrier Tape	Top Cover Tape	Bottom Cover Tape
Taping of Rectangularly Punched Carried System	Paper	thermal adhesion polyester	thermal adhesion paper

<b>ASJ</b>	LEAD FREE CHIP RESISTOR SPECIFICATION (HIGH VOLTAGE)	REV: D
	DOC NO: SYS-ENG-210	PAGE: 17 of 24

7.3 Leader and Trailer Tape

- 1) Leader Tape The length of leader tape shall be at least 500 mm including 40 or more or rectangular holes (component compartments) in which no component is placed.

The said 40 or more empty component compartments shall be sealed with the top cover tape (see Fig. 2).

- 2) Trailer Tape The trailer tape at the hub of reel shall be least 40 mm in length including carrier tape with empty component compartments. The empty component compartments shall be sealed with the top cover tape.

The last portion of the carrier tape shall release from the reel hub.

Fig. 2 Explanation of Leader and Trailer Tape

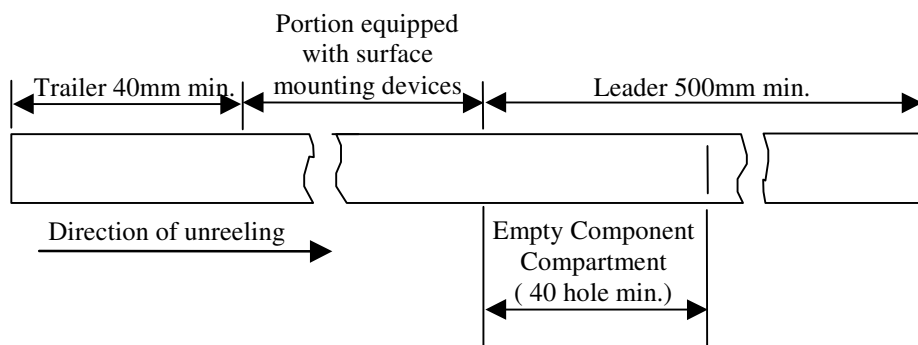

- 7.4 Position of Taped component The angle made by the center line of taped component and the center line of component compartment shall not exceed 20 degrees (see Fig. 3).

Fig. 3 Angle between Center Line of Component and Center Line of Component compartment

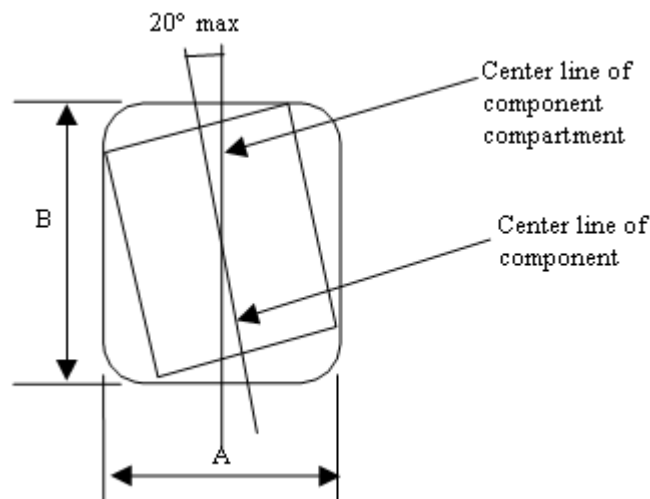

<b>ASJ</b>	LEAD FREE CHIP RESISTOR SPECIFICATION (HIGH VOLTAGE)	REV: D
	DOC NO: SYS-ENG-210	PAGE: 18 of 24

7.5 Dimension of Punched Paper Tape Carrier System (CR 24, 34, 42, 52, 66)

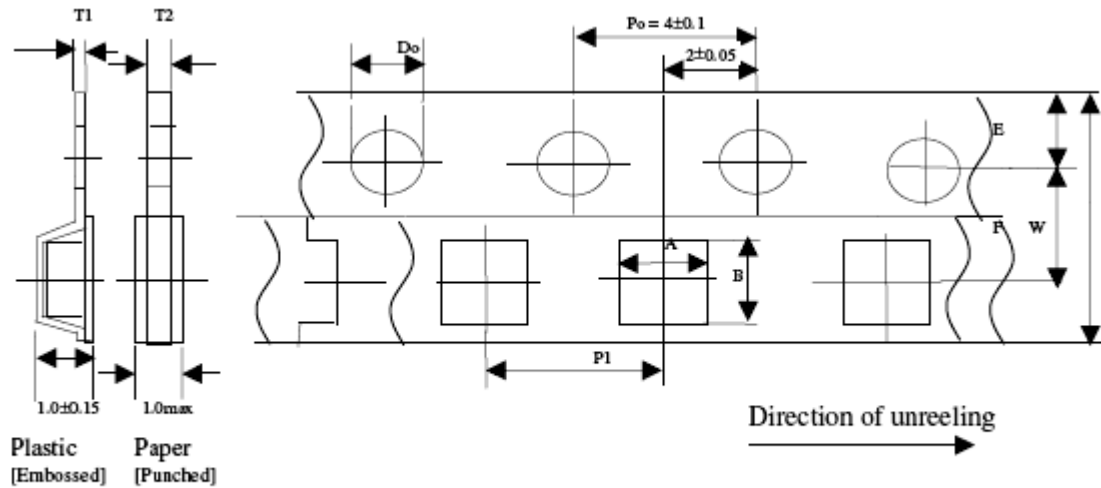

Remark : Pitch tolerance over any 10 pitches of  $P_0$  is  $\pm 0.2$  mm

Dimension of Punched Paper Tape Carrier System (CR – 24, 34, 42)

Code	A	B	W	E	F	P1	D0	T2
CR24	$1.65 \pm 0.1$	$2.4 \pm 0.1$	$8.0 \pm 0.2$	$1.75 \pm 0.1$	$3.5 \pm 0.05$	$4.0 \pm 0.1$	$1.5 \pm 0^{0.1}$	$0.75 \pm 0.1$
CR34	$1.9 \pm 0.1$	$3.5 \pm 0.1$						$0.75 \pm 0.1$
CR42	$2.8 \pm 0.1$	$3.5 \pm 0.1$						$0.75 \pm 0.1$

Dimension of Plastic Embossed Carrier System (CR – 52, 66)

Code	A	B	W	E	F	P1	D0	T1
CR52	$2.9 \pm 0.2$	$5.4 \pm 0.2$	$12 \pm 0.2$	$1.75 \pm 0.1$	$5.5 \pm 0.05$	$4.0 \pm 0.1$	$1.5 \pm 0^{0.1}$	$0.2 \pm 0.10$
CR66	$3.6 \pm 0.2$	$6.6 \pm 0.1$						

<b>ASJ</b>	LEAD FREE CHIP RESISTOR SPECIFICATION (HIGH VOLTAGE)	REV: D
	DOC NO: SYS-ENG-210	PAGE: 19 of 24

## 7.6 Performance of Taping

### 7.6.1 Strength of carrier tape and top cover tape

When a tensile force of 10N (1.02 kgf) is applied in the direction of unreeling the tape, the carrier tape and top cover tape shall withstand this force.

### 7.6.2 Peel force of top cover tape

- a) Ensure that the peel force meter is reset to  $\phi$  initially.
- b) A minimum of 4 holes is required when the top cover tape is pulled.
- c) Do not reset the peel force meter.
- d) The peel force of top cover tape shall be 0.1N to 0.7N (10 to 70 gf) when the top cover tape is pulled at a speed of 300 mm/min with the angle between the tape during peel and the direction of unreeling maintained at 165 to 180 degree as illustrated in Fig 4.

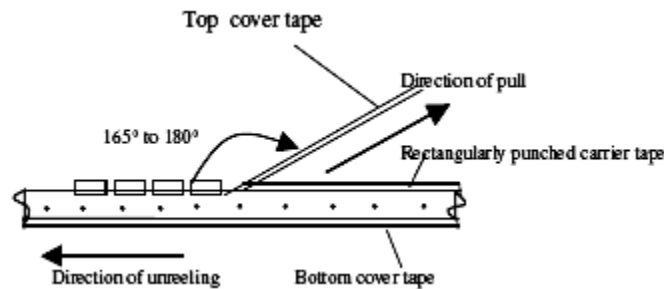

Fig. 4 Peeling Test

### 7.6.3 Minimum Bending Radius

When the tape is bent with the minimum bending radius specified in Fig 5 and Table 5, components shall maintain their position and shall be free from abnormalities such as damage.

Table 5

Width of Tape	Minimum Bending Radius
8 mm	30 mm
12 mm	30 mm

Fig. 5 Explanation of Minimum Bending Radius

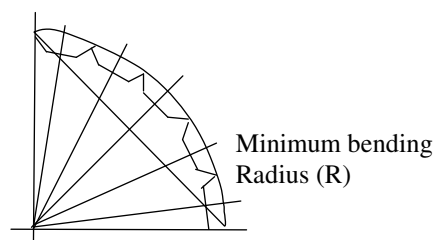

<b>ASJ</b>	LEAD FREE CHIP RESISTOR SPECIFICATION (HIGH VOLTAGE)	REV: D
	DOC NO: SYS-ENG-210	PAGE: 20 of 24

7.6.4 Numbering of missing components and mistake in taping

- a) The number of missing components shall not exceed 0.1% of the total number of components ( marked number ) or one whichever is the larger, and no consecutive missing chip exceeding two is allowed.
- b) No mistake is allowed on the position of polarity or termination or front and rear of component at the time of taping.

7.7 Packaging

7.7.1 Taping

7.7.1.1 Quantity – Tape and Reels

Code	Quantity	Remarks
CR24	5000 pcs	10 000 or 20 000 pcs on request
CR34		
CR42	5000 pcs	-
CR52	4000 pcs	-
CR66	4000 pcs	-

7.7.1.2 Quantity – Bulk Cassette

Code	Quantity	Remarks
CR24	10 000 pcs	
CR34	5000 pcs	-

7.7.2 Identification

Production label that indicates the 12 digits lot number, product type, resistance value and tolerance shall be pasted on the surface of each reel.



How to read lot Number:

XXXX      XX    XX    XXXX  
Year      Mth    Day    Serialize Number

<b>ASJ</b>	LEAD FREE CHIP RESISTOR SPECIFICATION (HIGH VOLTAGE)	<b>REV: D</b>
	DOC NO: SYS-ENG-210	PAGE: 21 of 24

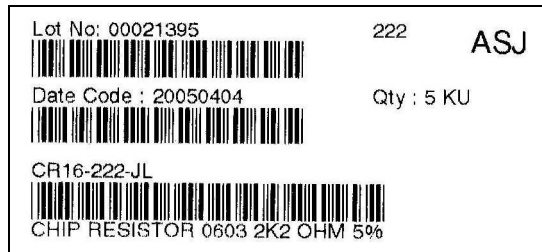

Lot Number : 8 digit running numbers

Date Code : YYYYMMDD

YYYY - Year  
 MM - Month  
 DD - Day



Lot Number : 8 digits running numbers

Date Code : YYYYMMDD

YYYY - Year  
 MM - Month  
 DD - Date

Manufacturing Part number  
 Part Description.

### 7.7.3 Packing Reel Box

Dimension	Reel Box	Number of Reels
185 × 60 × 186 mm	25K Box	5
185 × 120 × 186 mm	50K Box	10

<b>ASJ</b>	LEAD FREE CHIP RESISTOR SPECIFICATION (HIGH VOLTAGE)	REV: D
	DOC NO: SYS-ENG-210	PAGE: 22 of 24

7.7.4 Reel Dimensions

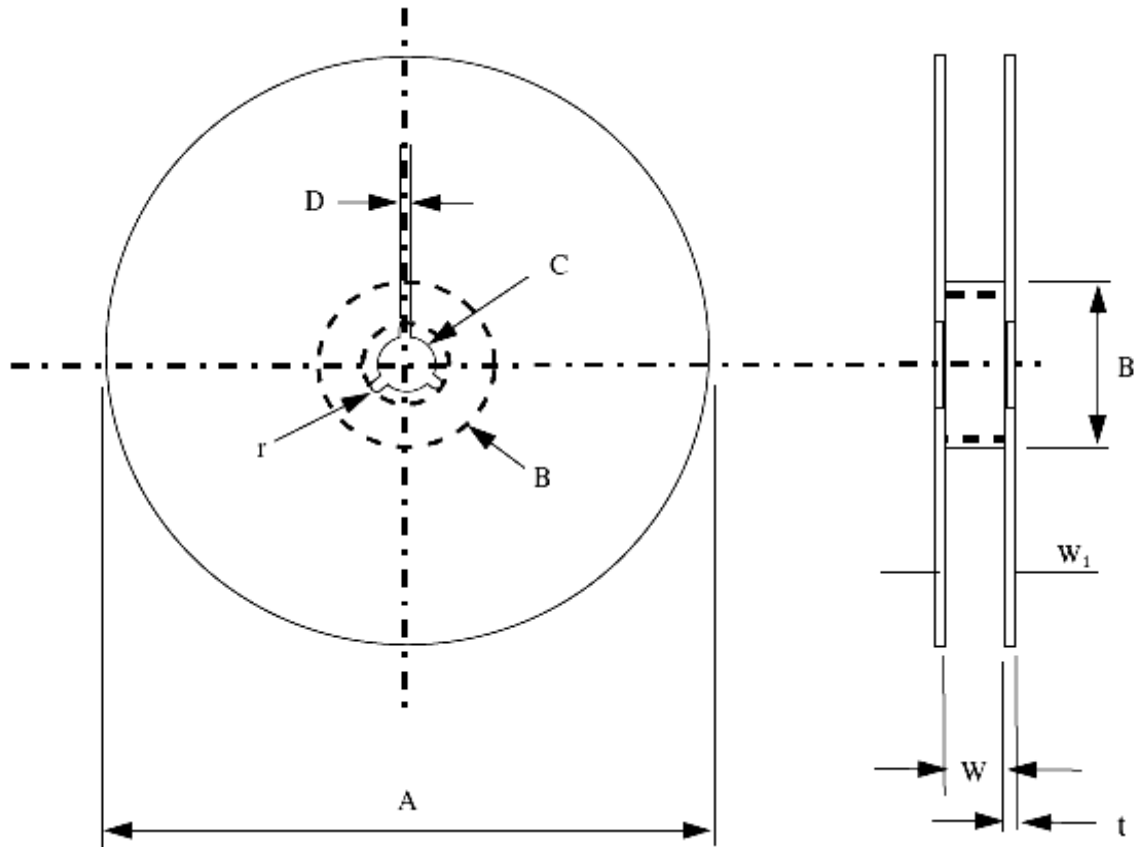

Model	A	B	C	D	W	W <sub>1</sub>	t	r
7"Reel (5K)	$\phi 178 \pm 2.0$	$\phi 80 \text{min}$	$13 \pm 0.2$	$\phi 2.0 \pm 0.5$	$11 \pm 0.1$	14.4 max	$1.0 \pm 0.1$	1.0
7"Reel (4K)	$\phi 178 \pm 2.0$	$\phi 60 \text{min}$	$13 \pm 0.2$	$\phi 2.0 \pm 0.5$	$13 \pm 1.0$	14.4 max	$1.2 \pm 0.1$	1.0
10"Reel (10K)	$\phi 254 \pm 2.0$	$\phi 60 \text{min}$	$13 \pm 0.2$	$\phi 2.0 \pm 0.5$	$11 \pm 1.0$	14.4 max	$1.5 \pm 0.1$	1.0
13"Reel (20K)	$\phi 330 \pm 2.0$	$\phi 60 \text{min}$	$13 \pm 0.2$	$\phi 2.0 \pm 0.5$	$11 \pm 1.0$	14.4 max	$2.1 \pm 0.1$	-

<b>ASJ</b>	LEAD FREE CHIP RESISTOR SPECIFICATION (HIGH VOLTAGE)	<b>REV: D</b>
	DOC NO: SYS-ENG-210	PAGE: 23 of 24

7.7.5 Bulk Cassette Packaging

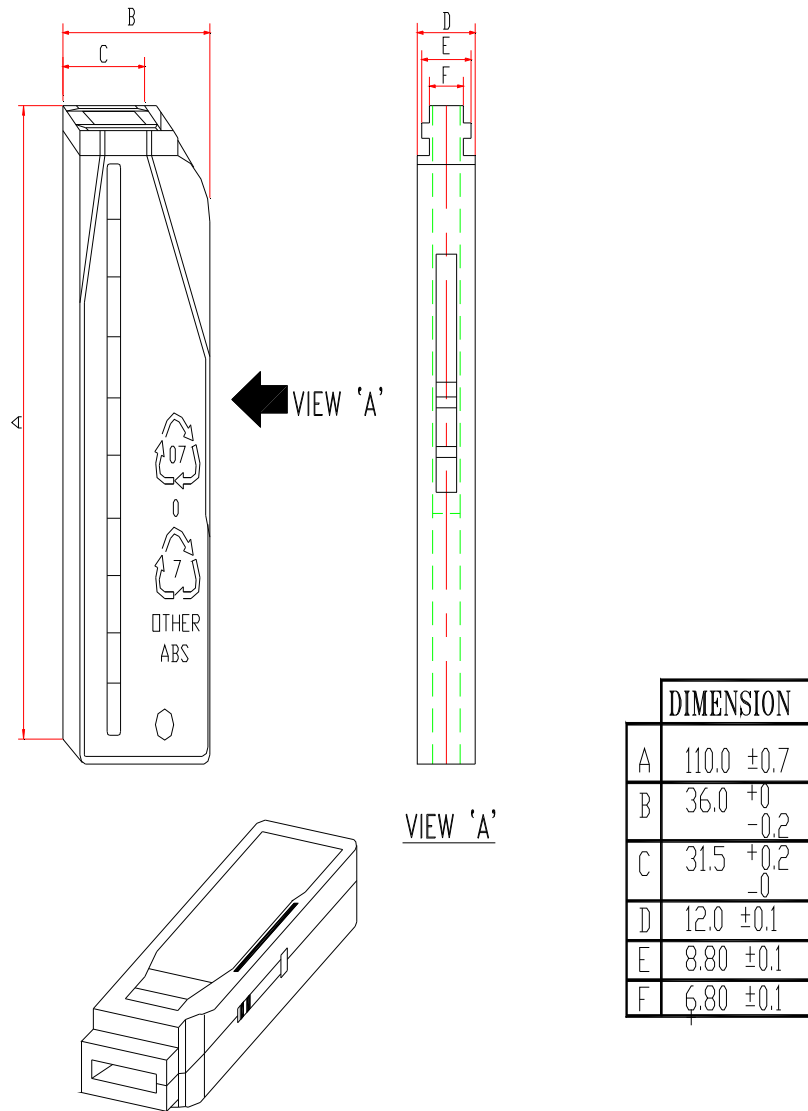

Bulk Cassette was standardized in March 1992 (EIAJ ET-7201)

<b>ASJ</b>	LEAD FREE CHIP RESISTOR SPECIFICATION (HIGH VOLTAGE)	<b>REV: D</b>
	DOC NO: SYS-ENG-210	PAGE: 24 of 24

## 8.0 Surface Mount Land Patterns

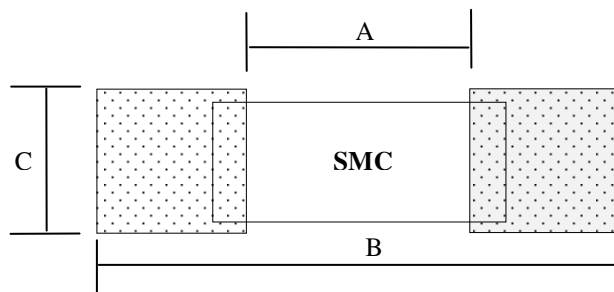

Product Type	Land Dimension		
	A	B	C
CR24 (0805)	0.047 [ 1.2 ]	0.138 [ 3.5 ]	0.043 ~ 0.051 [ 1.1 ~ 1.3 ]
CR34 (1206)	0.087 [ 2.2 ]	0.197 [ 5.0 ]	0.055 ~ 0.071 [ 1.4 ~ 1.8 ]
CR42 (1210)	0.087 [ 2.2 ]	0.197 [ 5.0 ]	0.083 ~ 0.118 [ 2.1 ~ 3.0 ]
CR52 (2010)	0.15 [ 3.9 ]	0.331 [ 8.4 ]	0.083 ~ 0.118 [ 2.1 ~ 3.0 ]
CR66 (2512)	0.205 [ 5.2 ]	0.413 [ 10.5 ]	0.098 ~ 0.189 [ 2.5 ~ 4.8 ]

## 9.0 APPLICABLE STANDARDS

JIS C 5202	Test Methods of Fixed Resistors for Electronic Equipment.
JIS C 5223	Fixed Thick Film Chip Resistors, Rectangular Type for Use in Electronic Equipment.
JIS C 0806	Packaging of Electronic Components on continuous tapes (surface mount devices).
MIL-R-55342	Resistors, Fixed, Film, Chip, Established Reliability, General Specifications for.
MIL-STD-202	Test Methods for Electronic and Electrical Parts.
IPC/JEDEC J STD 020	Moisture / Reflow sensitivity classification for non hermetic solid state surface mount devices.
2002/95/EC	RoHS Directive
IEC 60068-2-58	Solderability